

# MV-CS016-10GM/GC

1.6 MP 1/2.9" CMOS GigE Area Scan Camera



GEN<i>i</i>CAM

GIG<i>E</i>  
VISION

## Introduction

MV-CS016-10GM/GC camera adopts Sony® IMX296 sensor to provide high-quality image. It uses GigE interface to transmit non-compressed images in real time, and its max. frame rate can reach 65.2 fps in full resolution.

## Key Feature

- Adopts brand new design to reduce power consumption.
- Compact design with mounting holes on panels for flexible mounting from 4 sides.
- Supports noise reduction and color correction matrix function.
- Supports auto or manual adjustment for gain, exposure time, LUT, Gamma correction, white balance, etc.
- Adopts GigE interface and max. transmission distance of 100 meters without relay.
- Compatible with GigE Vision V2.0 Protocol, GenICam Standard, and third-party software based on the protocol and standard.

## Available Model

- Mono camera: MV-CS016-10GM
- Color camera: MV-CS016-10GC

## Applicable Industry

SMT/ PCB AOI, consumer electronics, electrical semiconductor, image measuring, etc.

## Sensor Quantum Efficiency

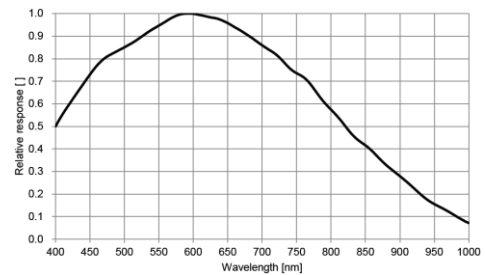

MV-CS016-10GM

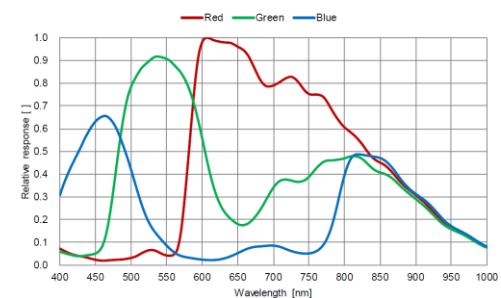

MV-CS016-10GC

## Dimension

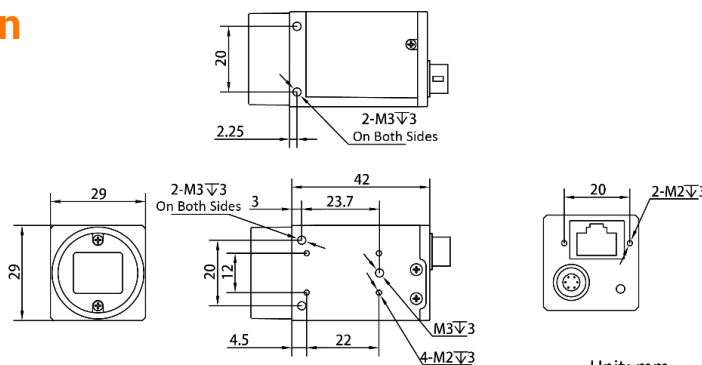

## Specification

Model	MV-CS016-10GM	MV-CS016-10GC
<b>Camera</b>		
Sensor type	CMOS, global shutter	
Sensor model	Sony® IMX296	
Pixel size	3.45 μm × 3.45 μm	
Sensor size	1/2.9"	
Resolution	1440 × 1080	
Max. frame rate	65.2 fps @ 1440 × 1080	
Dynamic range	74 dB	
SNR	41 dB	
Gain	0 dB to 24 dB	
Exposure time	UltraShort exposure mode: 1 μs to 14 μs	
	Standard exposure mode: 15 μs to 10 sec	
Exposure mode	Off/Once/Continuous exposure mode	
Mono/color	Mono	Color
Pixel format	Mono 8/10/12, Bayer RG	
	Mono 8/10/10p/12/12p, YUV422Packed, YUV422_YUYV_Packed, RGB 8, BGR 8	
Binning	Supports 1 × 1, 1 × 2, 1 × 4, 2 × 1, 2 × 2, 2 × 4, 4 × 1, 4 × 2, 4 × 4	
Decimation	Supports 1 × 1, 1 × 2, 1 × 4, 2 × 1, 2 × 2, 2 × 4, 4 × 1, 4 × 2, 4 × 4	
Reverse image	Supports horizontal and vertical reverse image output	
<b>Electrical features</b>		
Data interface	Gigabit Ethernet, compatible with Fast Ethernet	
Digital I/O	6-pin Hirose connector provides power and I/O, including opto-isolated input × 1 (Line 0), opto-isolated output × 1 (Line 1), bi-directional non-isolated I/O × 1 (Line 2).	
Power supply	9 VDC to 24 VDC, supports PoE	
Power consumption	Typ. 2.4 W @ 12 VDC	Typ. 2.5 W @ 12 VDC
<b>Mechanical</b>		
Lens mount	C-mount	
Dimension	29 mm × 29 mm × 42 mm (1.1" × 1.1" × 1.2")	
Weight	Approx. 100 g (0.22 lb.)	
Ingress protection	IP40 (under proper lens installation and wiring)	
Temperature	Working temperature: -30 °C to 60 °C (-22 °F to 140 °F)	
	Storage temperature: -30 °C to 70 °C (-22 °F to 158 °F)	
Humidity	20% RH to 80% RH (no condensation)	
<b>General</b>		
Client software	MVS or third-party software meeting with GigE Vision Protocol	
Operating system	32/64-bit Windows 7/10, 32/64-bit Linux	
Compatibility	GigE Vision V2.0, GenICam	
Certification	CE, RoHS, KC	