

Hikrobot Co., Ltd.

USB3.0 Area Scan Camera

User Manual

HIKROBOT

Legal Information

© Hangzhou Hikrobot Co., Ltd. All rights reserved.

About this Document

This Document includes instructions for using and managing the Product. Pictures, charts, images and all other information hereinafter are for description and explanation only. The information contained in the Document is subject to change, without notice, due to firmware updates or other reasons. Please find the latest version in the company website (<https://en.hikrobotics.com/>). Unless otherwise agreed, Hangzhou Hikrobot Co., Ltd. or its affiliates (hereinafter referred to as “Hikrobot”) makes no warranties, express or implied. Please use the Document with the guidance and assistance of professionals trained in supporting the Product.

Acknowledgment of Intellectual Property Rights

- Hikrobot owns the copyrights and/or patents related to the technology embodied in the Products described in this Document, which may include licenses obtained from third parties. Any part of the Document, including text, pictures, graphics, etc., belongs to Hikrobot. No part of this Document may be excerpted, copied, translated, or modified in whole or in part by any means without written permission.
- **HIKROBOT** and other Hikrobot's trademarks and logos are the properties of Hikrobot in various jurisdictions. Other trademarks and logos mentioned are the properties of their respective owners.

LEGAL DISCLAIMER

TO THE MAXIMUM EXTENT PERMITTED BY APPLICABLE LAW, THIS MANUAL AND THE PRODUCT DESCRIBED, WITH ITS HARDWARE, SOFTWARE AND FIRMWARE, ARE PROVIDED "AS IS" AND "WITH ALL FAULTS AND ERRORS". HIKROBOT MAKES NO WARRANTIES, EXPRESS OR IMPLIED, INCLUDING WITHOUT LIMITATION, MERCHANTABILITY, SATISFACTORY QUALITY, OR FITNESS FOR A PARTICULAR PURPOSE. THE USE OF THE PRODUCT BY YOU IS AT YOUR OWN RISK. IN NO EVENT WILL HIKROBOT BE LIABLE TO YOU FOR ANY SPECIAL, CONSEQUENTIAL, INCIDENTAL, OR INDIRECT DAMAGES, INCLUDING, AMONG OTHERS, DAMAGES FOR LOSS OF BUSINESS PROFITS, BUSINESS INTERRUPTION, OR LOSS OF DATA, CORRUPTION OF SYSTEMS, OR LOSS OF DOCUMENTATION, WHETHER BASED ON BREACH OF CONTRACT, TORT (INCLUDING NEGLIGENCE), PRODUCT LIABILITY, OR OTHERWISE, IN CONNECTION WITH THE USE OF THE PRODUCT, EVEN IF HIKROBOT HAS BEEN ADVISED OF THE POSSIBILITY OF SUCH DAMAGES OR LOSS.

YOU ACKNOWLEDGE THAT THE NATURE OF INTERNET PROVIDES FOR INHERENT SECURITY RISKS, AND HIKROBOT SHALL NOT TAKE ANY RESPONSIBILITIES FOR ABNORMAL OPERATION, PRIVACY LEAKAGE OR OTHER DAMAGES RESULTING FROM CYBER-ATTACK, HACKER ATTACK, VIRUS INFECTION, OR OTHER INTERNET SECURITY RISKS; HOWEVER, HIKROBOT WILL PROVIDE TIMELY TECHNICAL SUPPORT IF REQUIRED.

YOU AGREE TO USE THIS PRODUCT IN COMPLIANCE WITH ALL APPLICABLE LAWS, AND

YOU ARE SOLELY RESPONSIBLE FOR ENSURING THAT YOUR USE CONFORMS TO THE APPLICABLE LAW. ESPECIALLY, YOU ARE RESPONSIBLE, FOR USING THIS PRODUCT IN A MANNER THAT DOES NOT INFRINGE ON THE RIGHTS OF THIRD PARTIES, INCLUDING WITHOUT LIMITATION, RIGHTS OF PUBLICITY, INTELLECTUAL PROPERTY RIGHTS, OR DATA PROTECTION AND OTHER PRIVACY RIGHTS. YOU SHALL NOT USE THIS PRODUCT FOR ANY PROHIBITED END-USES, INCLUDING THE DEVELOPMENT OR PRODUCTION OF WEAPONS OF MASS DESTRUCTION, THE DEVELOPMENT OR PRODUCTION OF CHEMICAL OR BIOLOGICAL WEAPONS, ANY ACTIVITIES IN THE CONTEXT RELATED TO ANY NUCLEAR EXPLOSIVE OR UNSAFE NUCLEAR FUEL-CYCLE, OR IN SUPPORT OF HUMAN RIGHTS ABUSES.

THE PERFORMANCE DATA IN THIS PUBLICATION IS BASED ON HIKROBOT'S INTERNAL RESEARCH/EVALUATION. ACTUAL DATA MAY VARY DEPENDING ON SPECIFIC CONFIGURATIONS AND OPERATING CONDITIONS AND HIKROBOT SHALL NOT BEAR THE CONSEQUENCES ARISING THEREFROM.

IN THE EVENT OF ANY CONFLICTS BETWEEN THIS MANUAL AND THE APPLICABLE LAW, THE LATTER PREVAILS.

Regulatory Information



Note

These clauses apply only to the products bearing the corresponding mark or information.

EU Conformity Statement



This product and - if applicable - the supplied accessories too are marked with "CE" and comply therefore with the applicable harmonized European standards listed under the Directive 2014/30/EU(EMCD), Directive 2001/95/EC(GPSD) and Directive 2011/65/EU(RoHS).



2012/19/EU (WEEE directive): Products marked with this symbol cannot be disposed of as unsorted municipal waste in the European Union. For proper recycling, return this product to your local supplier upon the purchase of equivalent new equipment, or dispose of it at designated collection points. For more information see: <http://www.recyclethis.info>



Regulation (EU) 2023/1542(Battery Regulation): This product contains a battery and it is in conformity with the Regulation (EU) 2023/1542. The battery cannot be disposed of as unsorted municipal waste in the European Union. See the product documentation for specific battery information. The battery is marked with this symbol, which may include lettering to indicate cadmium (Cd), or lead (Pb). For proper recycling, return the battery to your supplier or to a designated collection point. For more information see: www.recyclethis.info.

This is a class A product. In a domestic environment this product may cause radio interference in which case the user may be required to take adequate measures.



KC Mark Certification

Class A: The device is advised to note that as a seller or a business user (Class A) Devices and intended for use outside the Home area.

A급 기기: 이 기기는 업무용(A급) 전자파적합기기로서 판매자 또는 사용자는 이 점을 주의하시기바라며, 가정 외의 지역에서 사용하는 것을 목적으로 합니다.

Symbol Conventions

The symbols that may be found in this document are defined as follows.

Symbol	Description
 Danger	Indicates a hazard with a high level of risk, which if not avoided, will result in death or serious injury.
 Caution	Indicates a potentially hazardous situation which, if not avoided, could result in equipment damage, data loss, performance degradation, or unexpected results.
 Note	Provides additional information to emphasize or supplement important points of the main text.

Available Model

This manual is applicable to the USB3.0 Area Scan Camera.

Contact Information

Hangzhou Hikrobot Co., Ltd.

E-mail: global.support@hikrobotics.com

Website: <https://en.hikrobotics.com/>

Contents

Chapter 1 Safety Instruction	1
1.1 Safety Claim	1
1.2 Safety Instruction	1
1.3 Electromagnetic Interference Prevention.....	3
Chapter 2 Cleaning Instruction	4
2.1 Device and Lens Cleaning	4
2.1.1 Rubber Dust Air Blower	4
2.1.2 Mirror Brush Cleaning	5
2.1.3 Contact Cleaning.....	5
2.1.4 Lens Cleaning Paper	6
2.2 Device Housing Cleaning	7
Chapter 3 Overview	8
3.1 Introduction	8
3.2 Key Feature.....	8
3.3 Operating Principle	8
Chapter 4 Device Hardware	10
4.1 Appearance.....	10
4.2 Power and I/O Connector	11
4.3 Indicator.....	12
Chapter 5 Power Supply and Heat Dissipation	13
5.1 Device Power Supply	13
5.1.1 USB Power Supply	13
5.1.2 DC Power Supply.....	13
5.2 Heat Dissipation.....	14
5.2.1 Temperature Parameter	14
5.2.2 Heat Dissipation Measures.....	16
5.2.3 Low Heat Conduction Material	17
Chapter 6 Accessories	19
6.1 Lens.....	19

6.1.1 Lens Mount.....	19
6.1.2 Lens Selection.....	19
6.2 Cable	20
6.2.1 Cable Selection	20
6.2.2 Wiring Principle.....	20
Chapter 7 Quick Start Guide	23
7.1 Device Installation	24
7.1.1 Installation Preparation.....	24
7.1.2 Install Device	24
7.2 Client Software Installation	25
7.3 Check Driver	27
7.4 Basic Operation.....	29
Chapter 8 I/O Electrical Features and Wiring	31
8.1 I/O Electrical Features	31
8.1.1 Input Signal	31
8.1.2 Output Signal.....	32
8.1.3 Bi-Directional Signal.....	34
8.1.4 Factors Affecting Transmission Delay of I/O Lines	37
8.2 I/O Wiring.....	38
8.2.1 Input Signal Wiring	38
8.2.2 Output Signal Wiring	39
8.2.3 Bi-Directional Signal Wiring	40
Chapter 9 Trigger Input and Output.....	44
9.1 Trigger Input.....	44
9.1.1 Set Trigger Mode.....	44
9.1.2 Set Trigger Source	45
9.1.3 Set Trigger Related Parameters	49
9.2 Trigger Output	56
9.2.1 Enable Line Inverter	56
9.2.2 Enable Strobe Signal	56
Chapter 10 Image Acquisition.....	62
10.1 Global Shutter and Rolling Shutter	62

10.1.1 Global Shutter	62
10.1.2 Rolling Shutter	62
10.2 Set Acquisition Mode	65
10.3 Non-Overlap Exposure and Overlap Exposure.....	65
10.3.1 Non-Overlap Exposure	65
10.3.2 Overlap Exposure	66
Chapter 11 Basic Functions.....	68
11.1 Set Frame Rate.....	68
11.2 Set Resolution and ROI	69
11.3 Set Image Reverse.....	71
11.4 Set Pixel Format	71
11.5 Set Image Compression Mode	74
11.6 Set Test Pattern	75
11.7 Set Binning	78
11.8 Set Decimation.....	79
11.9 Set Exposure Mode.....	80
11.9.1 Set Ultrashort Mode	80
11.9.2 Set Standard Mode	81
11.10 Set Brightness	81
11.11 Set Sharpness.....	83
11.12 Set Contrast Ratio	83
11.13 Set White Balance	84
11.14 Set Sequencer Control and HDR	85
11.14.1 Set Sequencer	86
11.14.2 Set HDR	88
11.15 Set Gain	89
11.15.1 Set Analog Gain	89
11.15.2 Set Digital Gain	90
11.16 User Set Customization	91
11.16.1 Save User Set.....	92
11.16.2 Load User Set.....	92
11.16.3 Set User Default.....	93

Chapter 12 Advanced Functions	94
12.1 Set Black Level.....	94
12.2 Set Gamma Correction	94
12.3 Set Digital Noise Reduction.....	97
12.4 Set AOI	97
12.5 Set Color Transformation Control.....	98
12.6 Set Hue	99
12.7 Set Saturation	101
12.8 Set Super Palette Control	102
12.9 Set Sensor Mode.....	103
12.10 Set WDR Mode	104
12.11 Set Shading Correction	105
12.11.1 LSC Correction.....	105
12.11.2 Other Corrections	107
12.12 Set LUT	108
Chapter 13 Other Functions.....	110
13.1 Device Control.....	110
13.2 Embedded Information.....	112
13.2.1 Watermark Settings.....	114
13.2.2 Chunk Settings.....	114
13.3 Event Control.....	115
13.4 Transport Layer Control	117
13.5 U3V Protocol Control	118
13.6 Transfer Control.....	119
13.6.1 User Controlled Transfer Control	119
13.6.2 Basic Transfer Control	120
13.7 File Access Control.....	121
13.8 Update Firmware.....	122
Chapter 14 FAQ (Frequently Asked Question).....	124
14.1 Why the client software cannot list devices?	124
14.2 Why device connection fails after the device is listed in the client software?..	124
14.3 Why the live view is black?	124

14.4 Why the device cannot be triggered although the live view is normal?	125
14.5 Why the device cannot get images required by the algorithm although live view and trigger signal are normal?	125
14.6 Why the device is offline during using?	125
Chapter 15 Revision History	126
Appendix A Device Parameter Index.....	128
A.1 Device Control	128
A.2 Image Format Control	129
A.3 Acquisition Control	130
A.4 Analog Control	132
A.5 Color Transformation Control	133
A.6 Super Palette Control	134
A.7 LUT Control	134
A.8 Shading Correction	134
A.9 Digital I/O Control	135
A.10 Counter and Timer Control	135
A.11 File Access Control.....	136
A.12 Sequencer Control	136
A.13 Event Control.....	137
A.14 Chunk Data Control	137
A.15 Transport Layer Control.....	137
A.16 Stream Control.....	138
A.17 Transfer Control.....	138
A.18 User Set Control	139

Chapter 1 Safety Instruction

The safety instructions are intended to ensure that the user can use the device correctly to avoid danger or property loss. Read and follow these safety instructions before installing, operating and maintaining the device.

1.1 Safety Claim

- To ensure personal and device safety, when installing, operating, and maintaining the device, follow the signs on the device and all safety instructions described in the manual.
- The note, caution and danger items in the manual do not represent all the safety instructions that should be observed, but only serve as a supplement to all the safety instructions.
- The device should be used in an environment that meets the design specifications, otherwise it may cause malfunctions, and malfunctions or component damage caused by non-compliance with relevant regulations are not within the scope of the device's quality assurance.
- Our company will not bear any legal responsibility for personal safety accidents and property losses caused by abnormal operation of the device.

1.2 Safety Instruction

Caution:

- Do not install the device if it is found that the device and accessories are damaged, rusted, water ingress, model mismatch, missing parts, etc., when unpacking.
- Avoid storage and transportation in places such as water splashing and rain, direct sunlight, strong electric fields, strong magnetic fields, and strong vibrations.
- Avoid dropping, smashing or vigorously vibrating the device and its components.
- It is forbidden to install the indoor device in an environment where it may be exposed to water or other liquids. If the device is damp, it may cause fire and electric shock hazard.
- Place the device in a place out of direct sunlight and ventilation, away from heat sources such as heaters and radiators.
- In the use of the device, you must be in strict compliance with the electrical safety regulations of the nation and region.
- Use the power adapter provided by the official manufacturer. The power adapter must meet the Limited Power Source (LPS) requirements. For the specific power consumption of the device, please refer to the device's specifications.
- Do not cover the device's plug or outlet for disconnecting power supply.
- It is strictly forbidden to wire, maintain, and disassemble the device is powered on.

Otherwise, there is a danger of electric shock.

- If the device emits smoke, odor or noise, please turn off the power and unplug the power cord immediately, and contact the dealer or service center in time.
- It is strictly forbidden to touch any terminal of the device when operating it. Otherwise there is a danger of electric shock.
- It is strictly forbidden for non-professional technicians to detect signals during device operation, otherwise it may cause personal injury or device damage.
- It is strictly forbidden to maintain the device is powered on, otherwise there is a danger of electric shock.
- Avoid aiming the lens at strong light (such as lighting, sunlight, or laser beams, etc.), otherwise the image sensor will be damaged.
- If it is necessary to clean the device, use a damp paper towel or a soft clean cloth to moisten a little pure water, gently wipe off the dust, and do not use alcohol-based corrosive solutions. Make sure to power off the device and unplug the power socket when cleaning.
- Keep clean of the device's image acquisition window. It is recommended to use cleaning water to wipe off the dust.
- If the device does not work properly, please contact your dealer or the nearest service center. Never attempt to disassemble the device yourself (we shall not assume any responsibility for problems caused by unauthorized repair or maintenance).
- Please dispose of the device in strict accordance with the relevant national or regional regulations and standards to avoid environmental pollution and property damage.

Note:

- Check whether the device's package is in good condition, whether there is damage, intrusion, moisture, deformation, etc. before unpacking.
- Check the surface of the device and accessories for damage, rust, bumps, etc. when unpacking.
- Check whether the quantity and information of the device and accessories are complete after unpacking.
- Store and transport the device according to the storage and transport conditions of the device, and the storage temperature and humidity should meet the requirements.
- It is strictly prohibited to transport the device in combination with items that may affect or damage the device.
- Quality requirements for installation and maintenance personnel:
 - Qualification certificate or working experience in weak current system installation and maintenance, and relevant working experience and qualifications. Besides, the personnel must possess the following knowledge and operation skills.
 - The basic knowledge and operation skills of low voltage wiring and low voltage electronic circuit connection.
 - The ability to comprehend the contents of this manual.
- Please read the manual and safety instructions carefully before installing the device.
- Please install the device strictly according to the installation method in this manual.
- The case of the device may be overheated, and it needs to be powered off for half an

hour before it can be touched.

- The device should not be placed with exposed flame sources, such as lighted candles.

1.3 Electromagnetic Interference Prevention

- Make sure that the shielding layer of cables is intact and 360° connected to the metal connector when using shielded cables.
- Do not route the device together with other equipment (especially servo motors, high-power devices, etc.), and control the distance between cables to more than 10 cm. Make sure to shield the cables if unavoidable.
- The control cable of the device and the power cable of the industrial light source must be wired separately to avoid bundled wiring.
- The power cable, data cable, signal cable, etc. of the device must be wired separately. Make sure to ground them if the wiring groove is used to separate the wiring and the wiring groove is metal.
- During the wiring process, evaluate the wiring space reasonably, and do not pull the cables hard, so as not to damage the electrical performance of the cables.
- If the device is powered on and off frequently, it is necessary to strengthen the voltage isolation, and consider adding a DC/DC isolation power supply module between the device and the adapter.
- Use the power adapter to supply power to the device separately. If centralized power supply is necessary, make sure to use a DC filter to filter the power supply of the device separately before use.
- The unused cables of the device must be insulated.
- When installing the device, if you cannot ensure that the device itself and all equipment connected to the device are well grounded, you should isolate the device with an insulating bracket.
- To avoid the accumulation of static electricity, ensure that other equipment (such as machines, internal components, etc.) and metal brackets on site are properly grounded.
- During the installation and use of the device, high voltage leakage must be avoided.
- Use a figure-eight bundle method if the device cable is too long.

Chapter 2 Cleaning Instruction

2.1 Device and Lens Cleaning

Four ways are available to clean the device and lens when they have dust or stains. Refer to the following table for different devices and their supported cleaning methods.

Table 2-1 Device and Cleaning Method

Cleaning Method \ Device	Camera	Lens
Rubber Dust Air Blower	Support	Support
Mirror Brush Cleaning	Not Support	Support
Contact Cleaning	Support	Support
Lens Cleaning Paper	Not Support	Support

2.1.1 Rubber Dust Air Blower

You can use a rubber dusk air blower to clean the dust on the surface of the device filter and lens. The specific operation steps are as follows:

Steps

1. Blow the rubber dusk air blower downward several times to blow out the dust inside.
2. Hold the device or lens and tilt it down so that the air blower port and the device lens are at an angle of 45 degrees.
3. Blow to clean the dust on the surface of the device filter and lens.



Figure 2-1 Cleaning by Rubber Dust Air Blower

Note

- Do not go too far into the device's lens mount and avoid direct contact with the dust glass when cleaning.
 - It is strictly forbidden to blow the lens directly from the mouth, and avoid spattering saliva particles onto the glass surface, causing serious secondary pollution.
-

2.1.2 Mirror Brush Cleaning

If the dust on the surface of the lens cannot be cleaned by rubber dusk air blower, use a mirror brush to gently remove the dust on the surface of the lens.

Note

Do not touch the bristles directly with your hands.

2.1.3 Contact Cleaning

For the stubborn stains on device filter or lens surface, such as finger marks, liquid stains, etc., it is recommended to use a fat-free cotton swab or dust-free cloth with high purity alcohol to wipe clean. Take the fat-free cotton swab as an example, and the specific operation steps are as follows:

Steps

1. Take a clean fat-free cotton swab, and dip it in proper amount of alcohol or cleaning liquid.

Note

Do not touch the head of the cotton swab by fingers.

2. Tilt the fat-free cotton swab about 60 degrees, resist the device filter or lens surface, clean from left to right, turn cotton swab over one side, and clean again from right to left.
3. Take another fat-free cotton swab that is not stained with alcohol or cleaning liquid and swipe the device filter or lens to absorb the remaining alcohol or cleaning liquid.
4. Check whether there is still a stain. If the stain changes position, repeat steps above, until the stain is cleaned.

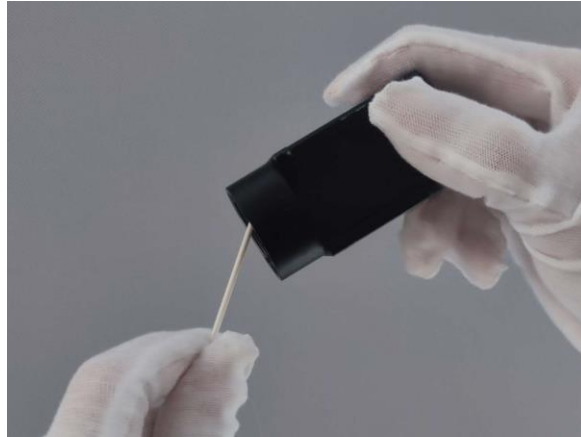

Figure 2-2 Contact Cleaning

Note

If the stains on the lens cannot be wiped or clean, please clean by using lens cleaning paper. For specific operation steps, please refer to the next section.

2.1.4 Lens Cleaning Paper

For lens stains that cannot be cleaned by a fat-free cotton swab or dust-free cloth, use lens cleaning paper to clean them.

Before You Start

- Use lens paper purchased from a regular, professional photography store.
- Use freshly opened lens cleaning paper in a wet state.
- Make sure there is no hard dust on the lens.

Tear off the outer package of the lens cleaning paper, fold the pre-moistened paper to a suitable wiping state, and slowly spiral wipe it in the same direction from the center of the lens outward.



Figure 2-3 Cleaning by Lens Cleaning Paper

Note

- Do not use hard paper, paper towels, or napkins to clean the lens. These products contain scratching wood pulp, which will seriously damage delicate coating on the lens.
 - Do not press the lens surface hard when cleaning it the lens cleaning paper. Otherwise, the fragile coating on the lens surface will be wiped off.
-

After completing the lens cleaning, no dust or water stains should be visible from all directions on the lens. If stains still exist, please contact us to return the device for cleaning.

2.2 Device Housing Cleaning

When cleaning the device, try to clean it in a closed room to avoid a large amount of dust in the environment. The specific operation steps are as follows:

Steps

1. Disconnect the device's power supply.
 2. Take a soft lint-free cloth that will not cause static electricity during cleaning and soak it with a neutral detergent.
 3. Wipe the device's housing with a soaked, lint-free cloth as appropriate.
 4. Wait for the residual moisture to evaporate after wiping. When the moisture has completely evaporated, you can reconnect the device to the power supply.
-

Note

Do not use compressed air to accelerate evaporation.

After inspecting and confirming that the device lens and its housing are cleaned, install the device lens cap with the mount facing downwards, or store the lens properly.

Chapter 3 Overview

3.1 Introduction

The USB3.0 area scan camera uses the USB3.0 interface to transmit non-compressed images in real time, and it can acquire images and set parameters via the client software.

3.2 Key Feature

- Supports auto and manual adjustment of gain, exposure time and white balance, and manual adjustment of Look-Up Table (LUT), Gamma correction, etc.
- Supports the hardware trigger, software trigger, anyway mode, etc.
- Supports image acquisition combined with multiple exposure modes.
- Adopts the image interpolation algorithm for the color reproduction.
- Supports customized ROI to improve frame rate via reducing resolution.
- Supports horizontal and vertical reverse image output.
- Supports Binning to increase sensitivity.
- Compact design for limited installation spaces.
- Adopts screw holes for fixing USB3.0 cable.
- Compatible with the USB3 Vision Protocol, the GenICam Standard, and the third-party software based on the protocol and standard.

Note

- The specific functions may differ by device models.
 - Refer to the device's specifications for specific parameters.
-

3.3 Operating Principle

The onboard block diagram of the device is shown below. After the image sensor receives the image data, it completes the image data processing through various built-in ISP image-processing algorithms, and finally completes the high-speed transmission of image data through the USB 3.0 interface.

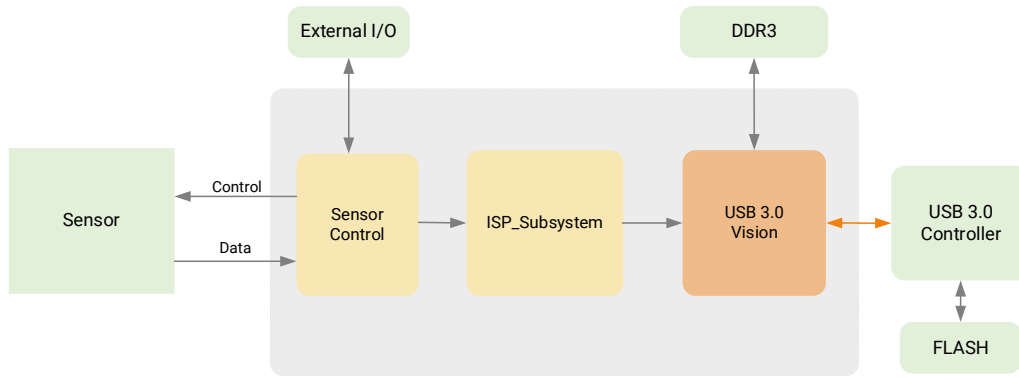

Figure 3-1 Operating Principle

Chapter 4 Device Hardware

4.1 Appearance

Note

- For specific appearance and dimension, please refer to the device's specification for details.
- The appearance is subject to change, and the actual device you purchased shall prevail.
- Only partial components are shown in this section.

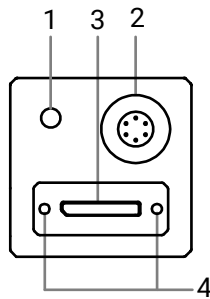

Figure 4-1 Appearance of Partial Components (Device with One USB Interface)

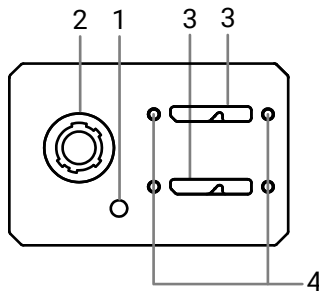

Figure 4-2 Appearance of Partial Components (Device with Two USB Interfaces)

Table 4-1 Component Description

No.	Component	Description
1	LED Indicator	It indicates the device's status. Refer to section Indicator .

No.	Component	Description
2	Power and I/O Interface	It refers to the power and I/O interface that provides power, and input/output signal. Refer to section Power and I/O Connector .
3	USB3.0 Interface	It is used to provide power and transmit data. Note Some device models are equipped with two USB interfaces.
4	USB3.0 Screw Hole	It refers to the M2 screw hole for fixing the USB3.0 cable.

Note

The camera connects to the lens via a C-mount, with a flange back length of 17.45 mm ± 0.15 mm.

4.2 Power and I/O Connector

The device has a 6-pin P7 connector as the power and I/O connector that provides power and I/O signals, as shown below.

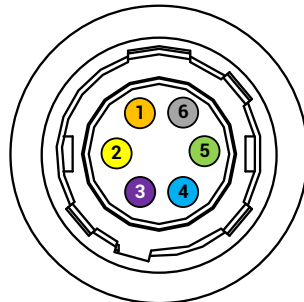

Figure 4-3 6-Pin P7 Connector

Table 4-2 Pin Definitions

No.	Cable Color	Signal	I/O Signal Source	Description
1	Orange	DC_PWR	--	Device power supply
2	Yellow	OPTO_IN	Line 0+	Opto-isolated input
3	Purple	GPIO	Line 2+	Can be configured as input or output
4	Blue	OPTO_OUT	Line 1+	Opto-isolated output
5	Green	OPTO_GND	Line 0-/1-	Opto-isolated signal ground
6	Gray	GND	Line 2-	Device power supply ground

 **Note**

- Refer to the table above and the label attached to the power and I/O cable to wire the device.
- The wire cores shown in figure and table are only the wire sequence and the corresponding wire core color of the cables sold by our company. If the cables are not purchased from our company, please refer to the actual wire sequence and the corresponding wire core color.

4.3 Indicator

The device's indicator is used to indicate the operation status of the device.

 **Note**

- When the indicator is flashing rapidly, flashing slowly, or flashing very slowly, its unlit interval is 0.2 sec to 0.3 sec, 1 sec, and 2 sec respectively. The duration of single lighting is 8 sec.
- The indicator sometimes may show a purple color when red and blue colors flashing at the same time.

Table 4-3 Indicator Description

No.	Indicator Color	Status	Device Status Description
1	Red	Flashing very slowly	The data cable is disconnected.
2	Blue	Solid	The device is in idle status. The data cable is connected, and the device is ready.
3	Blue	Flashing rapidly	The data cable is connected, and the device is acquiring images in the internal trigger mode. Data transmission speed reaches the rated speed of USB3.0.
4	Blue	Flashing slowly	The data cable is connected, and the device is acquiring images in the internal trigger mode. Data transmission speed reaches the rated speed of USB2.0.
5	Blue	Flashing very slowly	The data cable is connected, and the device is acquiring images in the external trigger mode.
6	Red and blue	Flash alternatively	The device firmware is updating.

Chapter 5 Power Supply and Heat Dissipation

5.1 Device Power Supply

The device provides two ways of power supply: USB power supply and external DC power supply.

When the external DC power supply and USB power supply are executed at the same time, the DC power supply takes priority. If the DC power supply is disconnected, the device will switch to USB power supply and may restart.

5.1.1 USB Power Supply

You can connect the device and the USB interface via the Micro USB3.0 (type B) cable for power supply.

5.1.2 DC Power Supply

Connect the external DC power supply to the I/O connector through the I/O cable to power the device. Refer to the device's label for the specific voltage range of power supply.

 **Note**

- Using a DC power supply that exceeds the specified voltage range may cause damage or abnormal operation of the device.
 - Inserting a connector that does not match the I/O connector may cause damage or abnormal operation of the device. Refer to section [Power and I/O Connector](#) for details.
 - Do not short-circuit the power supply and ground.
-

You can use an industrial power supply to provide DC power supply for the device. When using it, please observe the following precautions:

- Before carrying out any installation or maintenance work, make sure that the power supply is disconnected from the AC power and that there is no risk of accidental reconnection due to human negligence or wiring issues.
- Do not install the power supply in a humid environment, near liquid, in high-temperature conditions, in direct sunlight, or near flame sources.
- The industrial power supply has exposed high-voltage terminals. Please install it in an enclosed case or cabinet to prevent accidental contact by personnel.
- Maintain sufficient insulation distance between the internal components of the power supply and the screws.
- Ensure that the cooling fan and holes for heat dissipation are unobstructed. If adjacent equipment generates heat, keep it at least 10 cm to 15 cm away from the power supply.
- Make sure the power supply is properly grounded before use.

- When using the power supply, do not exceed the upper limit of its output current and output power. Refer to the power supply's nameplate for specific parameters.
- Non-standard installations or using the power supply in high-temperature environments will increase the temperature of the internal components, potentially reducing output power.
- The power supply contains high-voltage circuits that pose a risk. If any abnormalities occur, disconnect the power first and have it inspected by a technician with professional electrical qualifications. Do not attempt to open the casing yourself.
- Avoid touching the power supply terminals within 5 minutes after the power has been cut off to prevent the risk of electric shock.

5.2 Heat Dissipation

The device contains photosensitive components. If the device's temperature rises, it will have a certain impact on the quality of the acquired image. Based on the above situation, this section will introduce the temperature parameters and installation suggestions to achieve better heat dissipation effect and improve the image quality and reliability of the device.

5.2.1 Temperature Parameter

Working Temperature

The temperature of the key components of industrial cameras is a key factor affecting image quality, operation stability and long-term reliability. The upper limit of the working environment temperature in the specification of the industrial camera refers to the maximum ambient temperature that the device can meet without any additional heat dissipation measures. Running within the working temperature can meet the temperature requirements on the electronic components and ensure the reliable operation of the device.

The monitoring point of the working environment temperature of the device is 80 mm away from the main housing of the device, as shown below. In the space where the device and the temperature measuring point are located, there is no object in the middle and the temperature is evenly distributed. If the on-site installation environment can add some heat dissipation measures, the temperature of electronic components can be reduced, and the image quality and reliability of the device can be further improved.

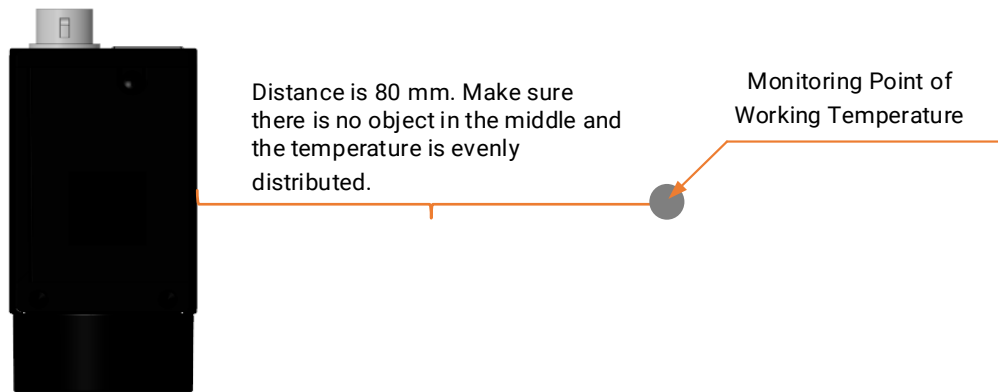

Figure 5-1 Monitoring Point of Working Temperature

Housing Temperature

After the heat generated by the electronic components is conducted to the device's housing, if the device does not have any additional heat dissipation measures, the heat is dissipated to the external environment in the form of convection and radiation through the device's housing.

The temperature of the device's housing will gradually rise during the heat dissipation process, and when the thermal equilibrium state is finally reached, the temperature tends to be stable. Therefore, we often feel that the device's housing has a certain temperature, or feel hot, which is a normal phenomenon of device heat dissipation.

Some components inside the device have done heat conduction measures to guide the heat to the housing to ensure that the temperature of the components meets the specification requirements, which also leads to a higher local temperature of the housing. Device's housing temperature is affected by power consumption, housing size, ambient temperature, and additional heat dissipation measures. Without additional heat dissipation measures, the temperature of the housing is the highest at this time. If some additional heat dissipation measures are added during field installation, the heat is dissipated to the external environment in the form of convection and radiation through the device's housing.

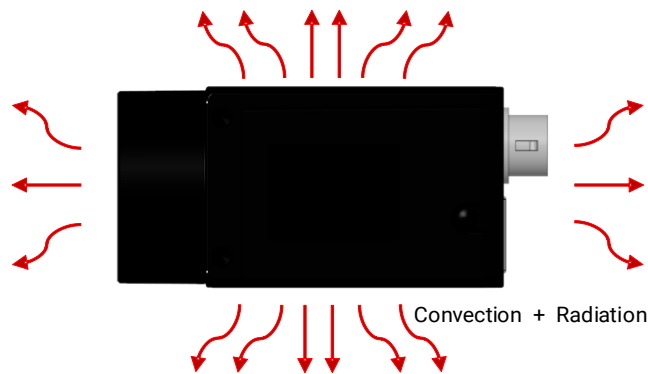

Figure 5-2 Housing Temperature

5.2.2 Heat Dissipation Measures

Heat Dissipation via Installation Part

Since most industrial cameras are fixed by the installation part, most of the heat can be guided to the metal mounting platform through the installation part during field installation, so as to dissipate the heat and greatly improve the heat dissipation efficiency of the device.

The heat discharged through the installation part depends on the heat conduction of the installation part itself and the installation method.

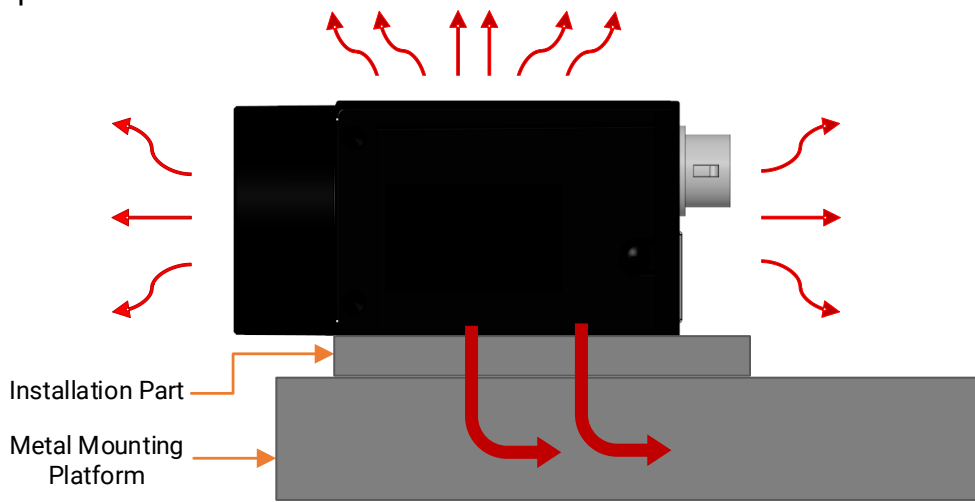

Figure 5-3 Heat Dissipation via Installation Part

- **Installation Part Material**

- Use materials with high heat conduction, such as aluminum and copper, which can quickly transfer heat away.
- Minimize the use of materials with low heat conduction, such as plastic and rubber.

Note

The heat dissipation mentioned in the following part (heat conduction path and contact area) is for materials with high heat conductivity.

- **Heat Conduction Path**

- The heat conduction path of the installation part should be as short as possible to improve the heat conduction efficiency.
- The thickness, length, and bending of the installation part will affect the heat conduction path distance of the device.

As shown in the installation method 1 and 2 in the figure below, the thickness of the installation part should be reduced as much as possible to shorten the heat conduction path from the device to the metal mounting platform via the installation part.

As shown in the installation method 3 and 4 in the figure below, the extension of the length of the installation part and the use of bent metal will lead to the lengthening of the heat conduction path of the device.

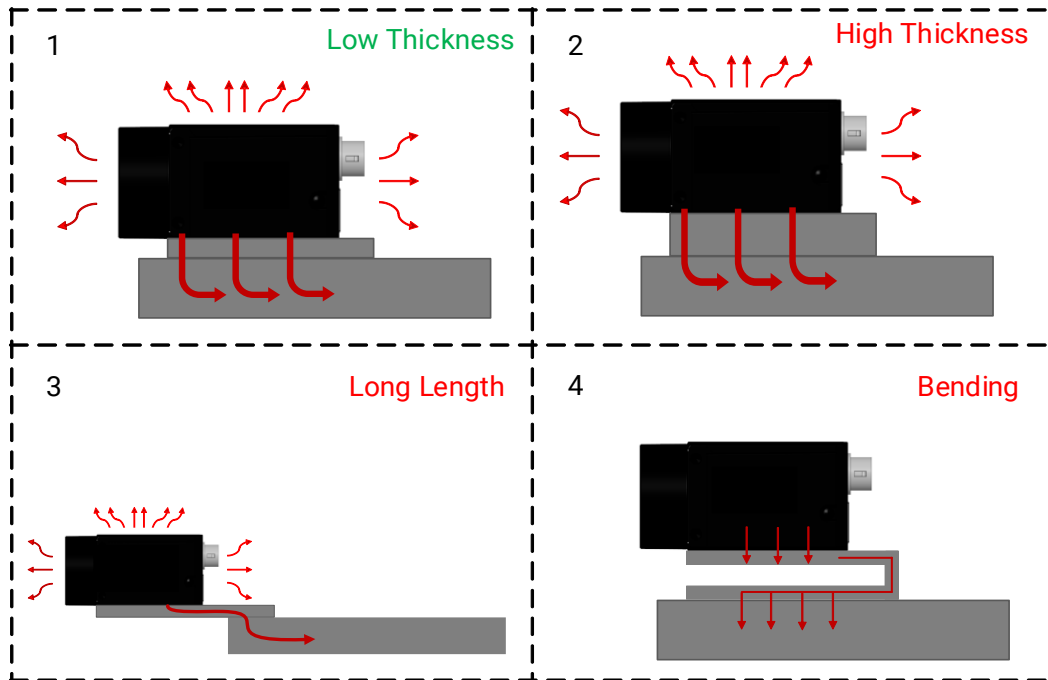

Figure 5-4 Heat Conduction Path of Different Installation Methods

- **Installation Part Section**

The cross section area along the heat conduction direction should be as large as possible, so that the heat conduction resistance can be reduced. For some installation parts have to use extended or bent metal (as shown in installation methods 3 and 4 in figure above), the thickness of the sheet metal needs to be increased as much as possible to increase the cross section of the device heat conduction path and strengthen the heat conduction.

- **Contact Area**

Surface contact should be used among the device, installation parts and the mounting platform, and the contact area between installation surfaces should be increased as much as possible to improve the heat dissipation of the device. The flatness of the installation part should be within 0.1 mm, in case the actual contact surface is not completely close, affecting the heat dissipation effect.

Heat Dissipation via Cooling Fan

For cases where the installation parts are made of plastic and other materials with poor heat conduction, ventilation equipment such as cooling fans and air conditioners can be used to increase the air flow on the surface of the device and reduce the air temperature around the device, thereby enhancing the convective heat dissipation of the device into the air.

5.2.3 Low Heat Conduction Material

If the mounting platform is made of materials with very poor heat conduction such as

plastic and wall, heat dissipation can be improved in the following ways:

- Increase the surface area of the installation part.
If the installation part is in good contact with the device, it can be regarded as a part of the device's housing. The larger the heat dissipation area of the housing, the better the heat dissipation effect. Therefore, the larger the surface area of the installation part, the better the heat dissipation effect.
- The installation part can be made into a metal heat dissipation tooth shape, or a large area flat plate to improve the heat dissipation effect.

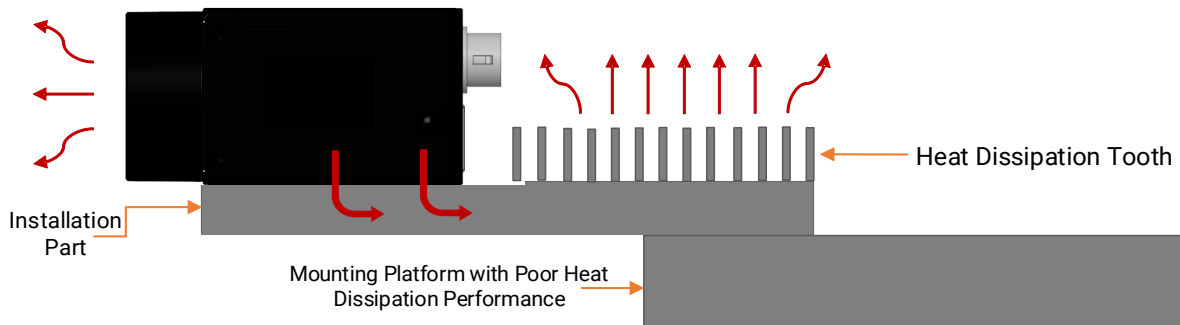

Figure 5-5 Add Heat Dissipation Tooth

- The surface of the installation part should be in contact with air as much as possible, not with a mounting platform with poor heat conduction.
- While increasing the heat dissipation area of the installation part, painting and oxidation can be used to increase the radiation heat exchange of the installation part to the external environment and strengthen the heat dissipation of the device.

Chapter 6 Accessories

6.1 Lens

6.1.1 Lens Mount

The device supports standard C-mount lenses which can be connected to other lenses via the adapter ring.

6.1.2 Lens Selection

In order to meet the image acquisition needs of industrial cameras, our company provides the standard C-mount lenses with high performance, high definition, low distortion rate, and other features. You should consider following factors when selecting a lens:

- **Sensor size:** Make sure that the target surface of the lens is larger than or equal to the size of the device's sensor.
- **Resolution:** It represents the ability of the lens to record the details of an object. It is generally measured in the number of line pairs that can be distinguished per millimeter: line pairs/millimeter (lp/mm). The higher the resolution of the lens, the clearer the image. Make sure that the accuracy required by the system is less than the resolution of the lens when selecting the lens.
- **Working distance:** It refers to the distance from the first working surface of the lens to the measured object. Make sure that the working distance is greater than the minimum object distance of the lens when selecting a lens.
- **Focal length:** The distance from the center point of the lens to the clear image formed on the focal plane. The smaller the focal length value is, the larger the field of view of the image captured by the digital camera is. According to the focal length of the lens, the appropriate working distance can be set up, or the appropriate lens can be selected according to the requirements of the working distance.

Note

In order to better provide a suitable lens model, you can go to the official website of our company (<https://en.hikrobotics.com/>): **Products** → **Lens** → **Lens Selector** to enter your application parameters, and you will find a suitable lens model. If you have any problems, please contact our technical support.

6.2 Cable

6.2.1 Cable Selection

According to the cable performance, it can be divided into standard, flexible, high flexible and super flexible cables. You need to select cables according to different scenarios.

- Standard cable: It is applicable to static scenario only.
- Flexible cable: It can withstand 100,000 times of drag chain or bending movement.
- High flexible cable: It can withstand 5 million times of drag chain movement.
- Super flexible cable: It can withstand 10 million times of drag chain movement, 3 million times of bending movement or 5 million times of twisting movement.

6.2.2 Wiring Principle

Regarding the power and I/O cable and network cable, attention should be paid to the application requirements of scenarios such as high-frequency communication and high-frequency motion. In such scenarios, if the cables are arranged in an inappropriate manner, various problems may be caused in use, such as cable skin wear, internal conductor breakage, and device packet loss. Based on the above situation, this section introduces the basic wiring principles and precautions of sports cables to help you install and use related products correctly and improve the overall healthy operating life of the system.

- The minimum bending radius of the chain rail during wiring should be controlled at more than 10 to 12 times the wire diameter (the larger the bending radius, the longer the cable movement life).
- Make sure that the cable does not spin in the chain rail, and the cable should be spread horizontally along the chain rail.
- If the cable is laid too tightly, the cable sheath and the chain rail will produce friction during the movement, which will cause the sheath to wear. Therefore, in the wiring process, the laying tension on the cable should be avoided.
- If the cable is fixed at the moving part of the chain rail, stress concentration will occur at the fixed position during the movement. Therefore, both ends of the cable can be fixed, but not at the middle moving section.
- Multiple cables may interfere with each other when moving in the chain rail. At this time, the chain rail with sufficient width should be selected to ensure that there is still a certain space after the cables are laid horizontally. The use of spacers is also an effective way to avoid interference. Note that there should also be at least 2 mm clearance between the spacer and the cable. Do not drain cables without spacers.
- Please keep the space factor occupied by the cable after laying within 30%, as shown below.

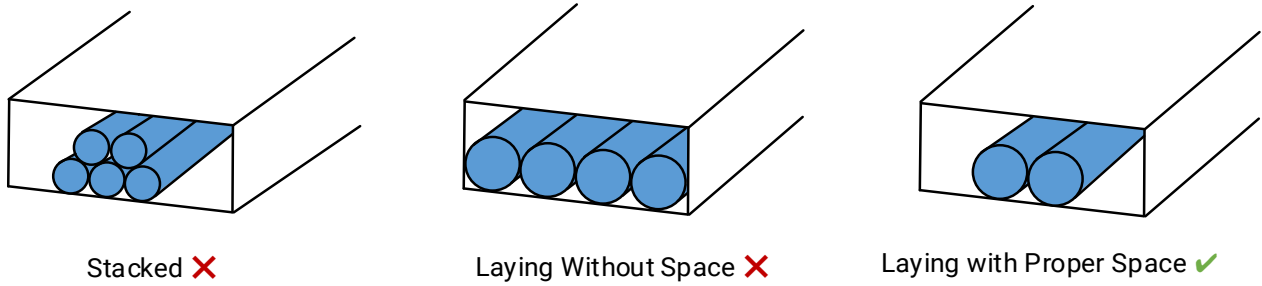

Figure 6-1 Cable Laying

- In the same chain rail, if there are cables with different thicknesses and diameters, the cables with small outer diameter are easily squeezed to the bottom by the cables with large outer diameter. In this case, use spacers for classification and isolation, as shown below.

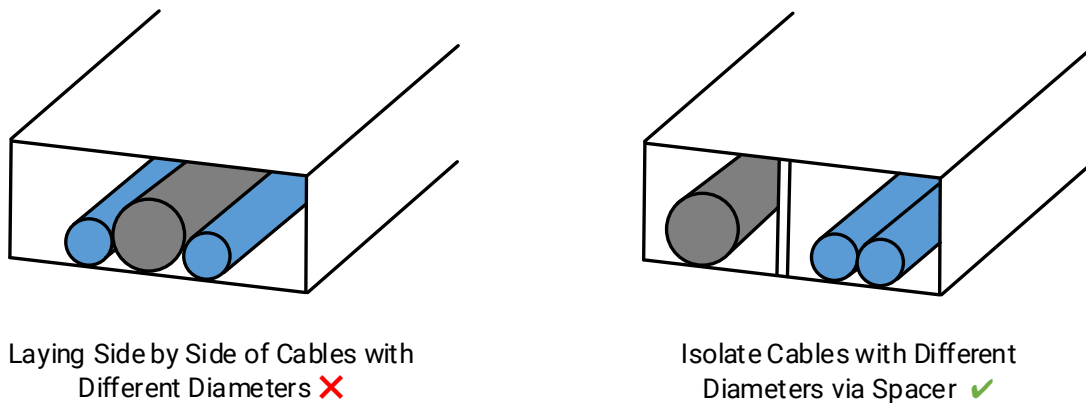

Figure 6-2 Isolated via Spacer

- If the wiring is in the same track as the hard object such as the air pipe, use a spacer to isolate it.
- If the chain rail is damaged, replace the chain rail and cable at the same time, because the damaged chain rail may aggravate the damage to the cable.
- Do not bend the cable vertically on the fixed point.

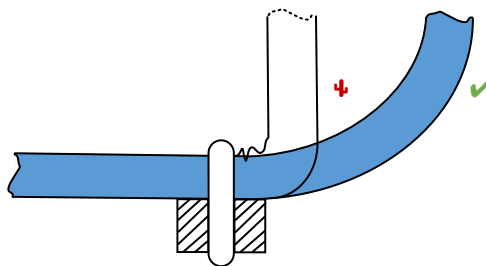

Figure 6-3 Vertically Bended Prohibited

- Make sure to reserve a suitable bending length for the cable.

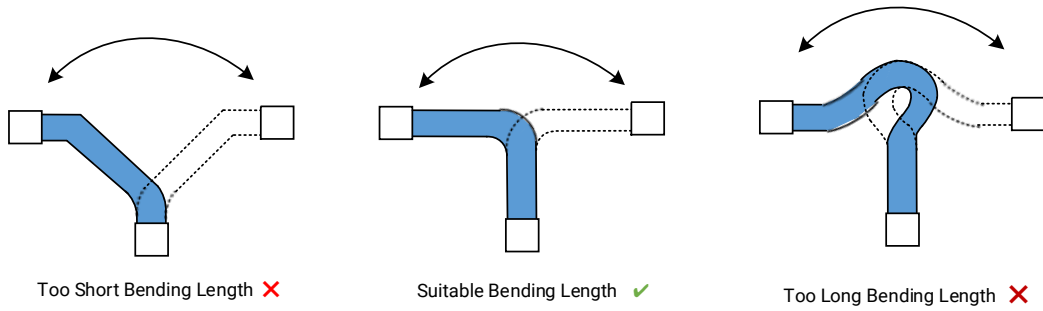

Figure 6-4 Suitable Bending Length

- Please keep a sufficient bending radius.

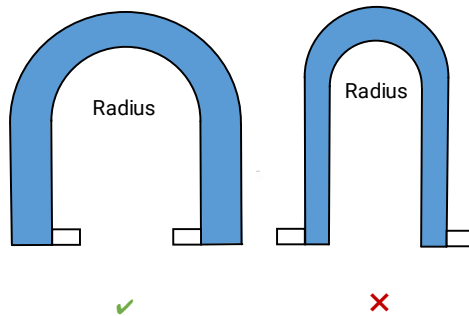

Figure 6-5 Sufficient Bending Radius

- When assembling the connector, please fix it on the connector net tail instead of the cable body.

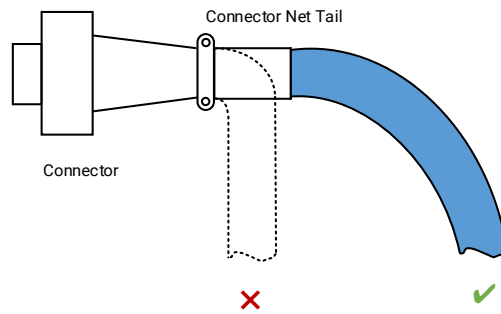

Figure 6-6 Assemble Connector

- Do not bind cables of different diameters together.

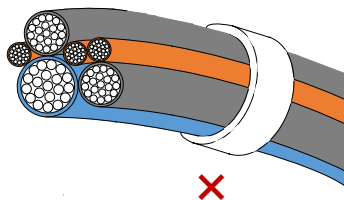

Figure 6-7 Improper Binding

Chapter 7 Quick Start Guide

The overall workflow of using the device is shown below:

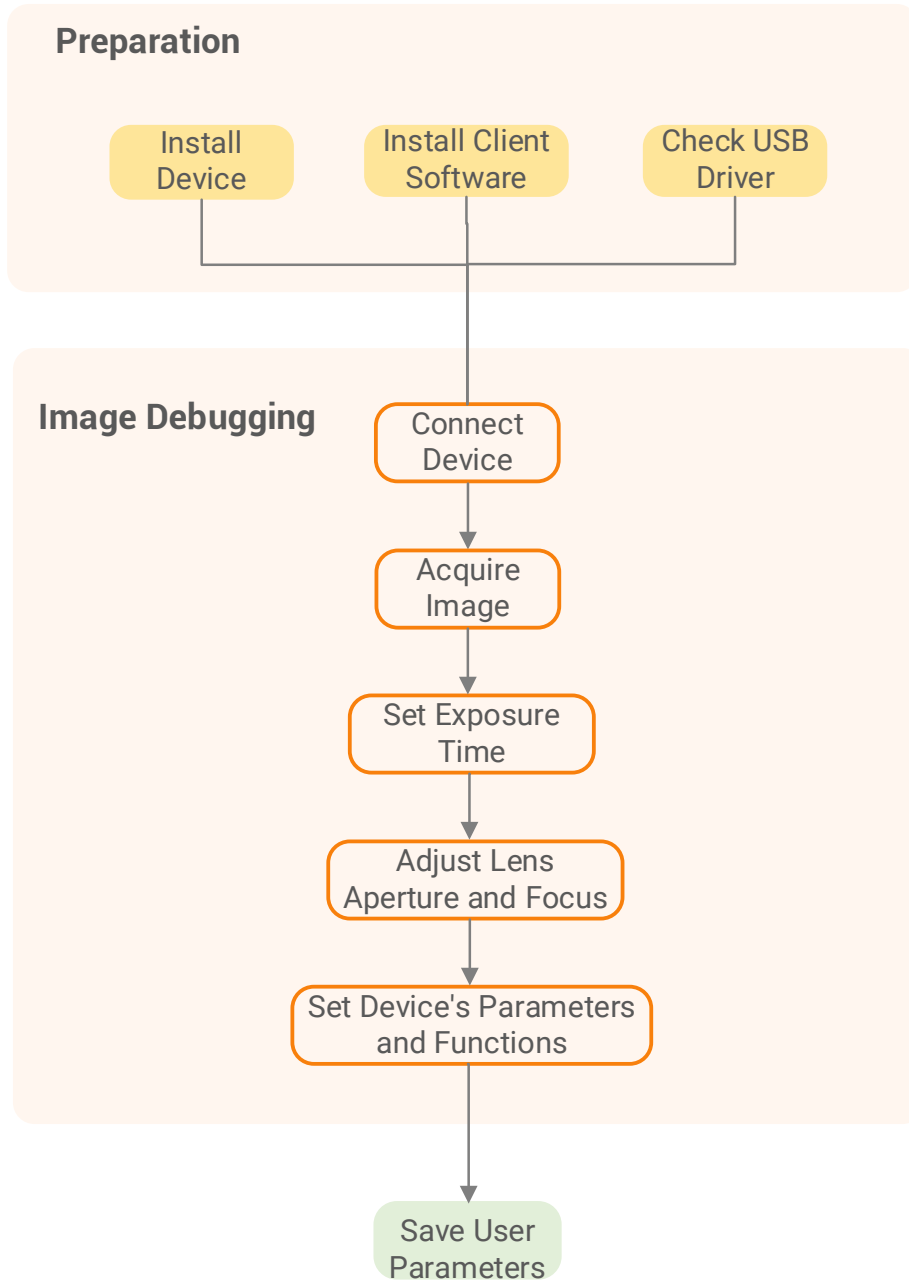

Figure 7-1 Workflow

7.1 Device Installation

7.1.1 Installation Preparation

You need to prepare following accessories before device installation.

Table 7-1 Accessories

No.	Name	Quantity	Description
1	Power and I/O Cable	1	It refers to the 6-pin power and I/O cable. You need to purchase separately.
2	DC Power Supply	1	You should select suitable power adapter or switch power supply according to the device power supply and consumption. You need to purchase separately.
3	USB3.0 Cable	1	It refers to the Micro USB3.0 (type B) cable. You need to purchase separately.
4	Lens	1	It refers to the C-mount lens. You need to purchase separately.

Note

- The device mentioned in this manual is an electronic product that requires operation and storage under dry conditions. In case of hot and humid, acidic and alkaline environment, please take isolation and protection measures to avoid corrosion damage of the device's internal components.
- When using the lens, it is necessary to prevent humid environment and avoid steam from entering inside, causing fogging.

7.1.2 Install Device

The topology diagram of the device is shown below.

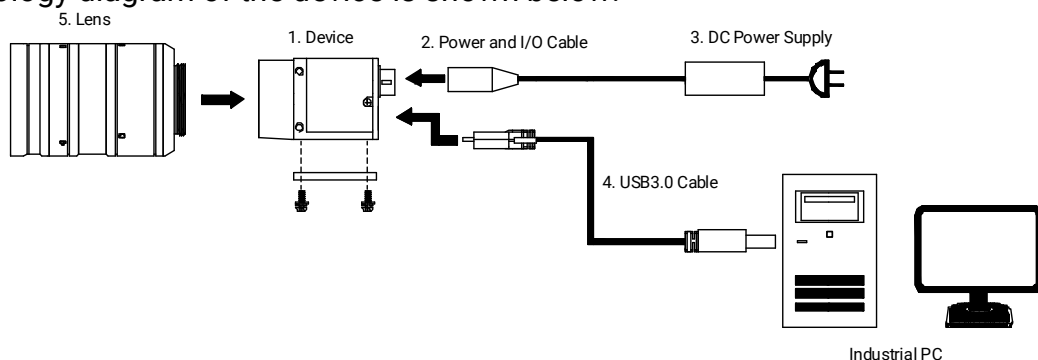

Figure 7-2 Topology Diagram

Note

- The topology diagram is for reference only.
 - If there is no available USB3.0 interface on the industrial PC, you can connect the device to the PC via a USB expansion card.
-

Before You Start

- Make sure the device in the package is in good condition and all the assembly parts are included.
- Make sure all the related equipment is powered off during the installation.

Steps

1. Fix the device to the installation position.
 2. Install the C-mount lens to the device.
-

Note

During device installation, heat dissipation measures of installation parts can be taken to improve the efficiency of heat dissipation. Refer to section [Heat Dissipation Measures](#) for details.

3. Use the Micro USB3.0 (type B) cable to connect the device to the industrial PC or other devices.
-

Note

Use the USB3.0 cable to ensure sufficient bandwidth for real-time image transmission.

4. Select one of the following methods for power supply.
 - Direct power supply: Use the 6-pin power and I/O cable to connect the device to a proper power adapter. Refer to section [Power and I/O Connector](#) for details.
 - USB power supply: Use the USB3.0 cable to connect the device to the PC or other devices via USB3.0 interface.

7.2 Client Software Installation

MVS client software is used to connect and set device's parameters, and acquire images.

Note

- The MVS client software is compatible with 32/64-bit Windows 7/10, 64-bit Windows 11, 32/64-bit Linux, and Android 4.4 to 9.0 operating systems. Here we take Windows as an example.
 - The graphic user interface may differ by different versions of the client software you use.
 - The client software has integrated driver required by hardware, and no need to download and install other drivers.
 - You can download the client software from en.hikrobotics.com.
-

Steps

1. Double click the MVS installation package.
2. Select the language.
3. Read and check **Terms of the License Agreement**.

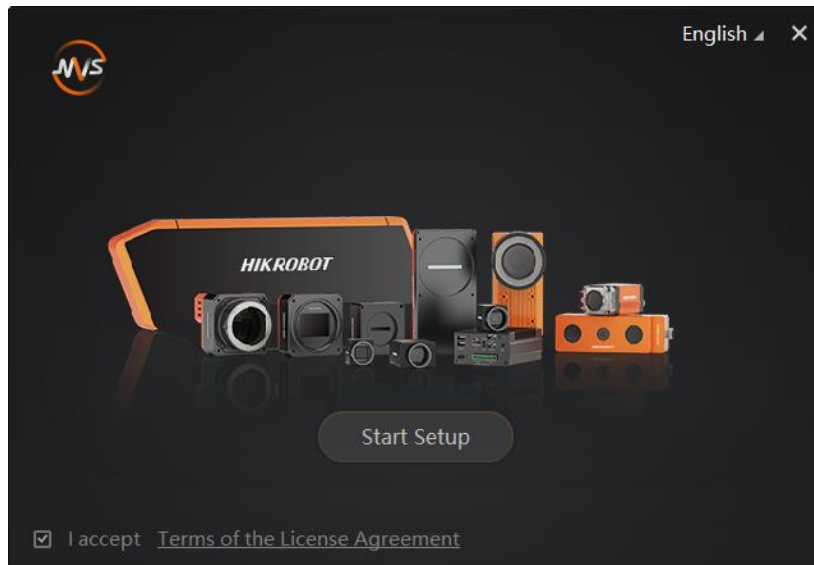

Figure 7-3 Installation Interface

4. Click **Start Setup**.
5. Select installation directory, driver and others.
 - **Select Driver:** You can check **GIGE**, **USB 3.0** and **PCIE** according to actual demands.
 - **Others:** Check **Enable built-in debug features** to make it easier to use breakpoints while the device is connected and streaming images. Check **Enable Jumbo Frame for All NICs** to enhance network transmission performance. Check **PCIE-CML**, **PCIE-CXP**, **PCIE-GEV**, **PCIE-XoF** to enumerate the corresponding frame grabbers.

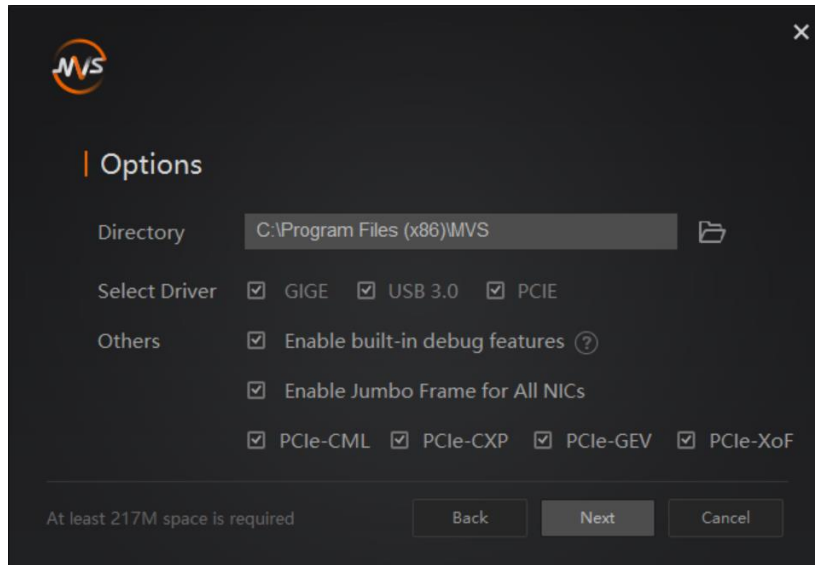

Figure 7-4 Installation Options

Note

- Regarding options, it is recommended to keep default settings.
- **PCle-CML**, **PCle-CXP**, **PCIE-GEV**, **PCIE-XoF** can be checked only when **PCIE** is selected.
- **PCle-CML**, **PCle-CXP**, **PCIE-GEV**, **PCIE-XoF** supports frame grabbers developed by our company only.

6. Click **Next** to install.

7. Finish the installation process according to the prompts.

7.3 Check Driver

Note

Before using the device, you need to make sure that the PC has installed the USB driver correctly. Otherwise, the client software cannot find the device.

After connecting the device, the PC will automatically check and install the USB driver. After installation, you can view the added driver in the device manager of the PC, and right click **Properties** to view its properties.

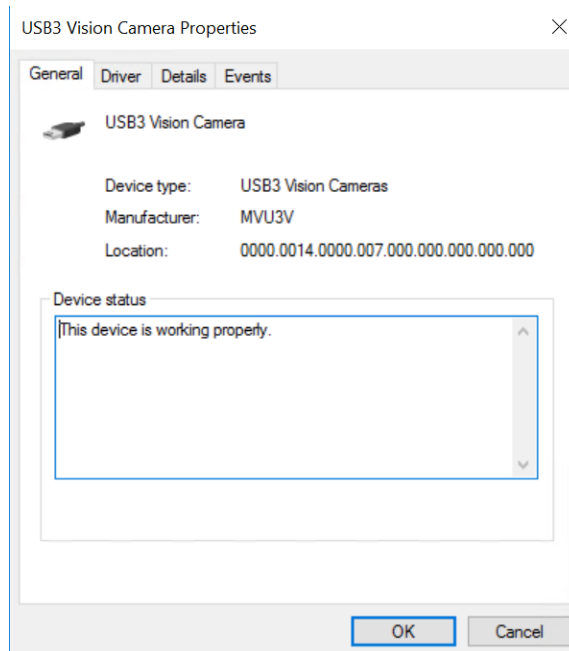

Figure 7-5 Driver Properties

If the installation of the driver is failed, you can use the driver installation tool to install the driver again manually. Go to **Start** → **MVS Folder** → **Tools**, click **Driver_Installation_Tool** to run it, and click **Uninstall** or **Install** of the corresponding driver to uninstall or install the driver again.

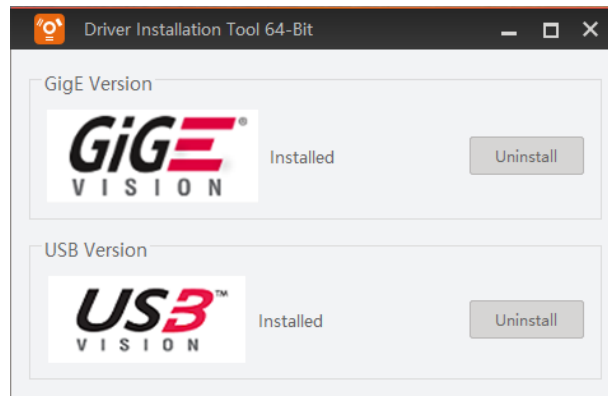

Figure 7-6 Driver Installation Tool

Note

The specific path of finding the driver installation tool may differ by Windows version and the client software version you installed.

7.4 Basic Operation



Steps

Note

Refer to the user manual of the device and client software for detailed operations.

1. Run the MVS client software, and the client software will enumerate the device automatically.

Note

- If the device cannot be enumerated, you can click  to refresh the device list.
- If the enumerated device is displayed with a icon , it means that there is an exception in the USB driver. Refer to section [Check Driver](#) to reinstall the USB driver.

2. Double click the device model for connection.

The client software displays the device's information, as shown below.

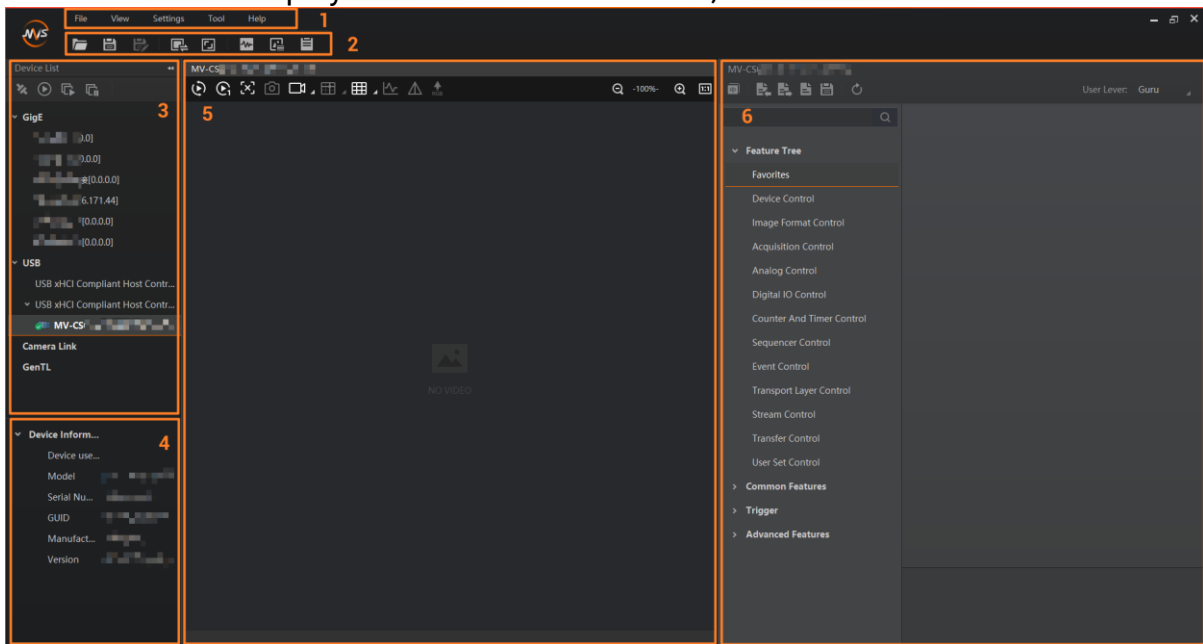

Figure 7-7 Main Window

Note

For specific main window of the client software, please refer to the actual one you got.

Table 7-2 Main Window Description

No.	Name	Description
1	Menu Bar	The menu bar displays function modules, including File, View, Settings, Tool, and Help.

No.	Name	Description
2	Control Toolbar	The control toolbar provides quick operations for the device.
3	Device List Panel	This panel displays the list of devices, and you can connect or disconnect device.
4	Device Information Panel	This panel displays the detailed information of connected device.
5	Display Window	This area displays the acquired images in real time.
6	Feature Panel	This panel displays the device's parameters, and you can configure them according to actual demands.

3. Set the device's pixel format, exposure time, etc., in the feature panel.
4. Click  in the display window to acquire images continuously.
5. Adjust the device's aperture and focus to have clear images.
6. (Optional) Set the device's other parameters in the feature panel.

 **Note**

The device's feature panel and parameters may differ by device models.

Chapter 8 I/O Electrical Features and Wiring

8.1 I/O Electrical Features

8.1.1 Input Signal

The internal circuit of opto-isolated input (Line 0) is as follows.

Note

- The maximum input current of Line 0 is 25 mA.
- Make sure that the input voltage is not from 1 VDC to 3.3 VDC, because the electric status between these two values are not stable.
- The breakdown voltage is 30 VDC. Keep voltage stable.

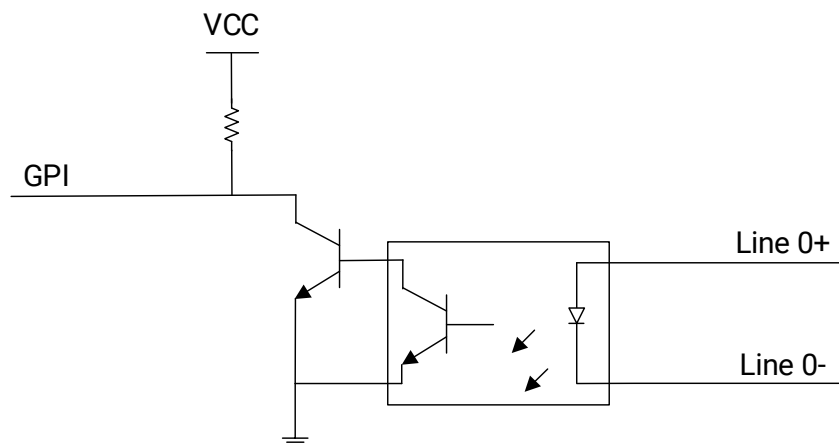

Figure 8-1 Internal Circuit of Input Signal

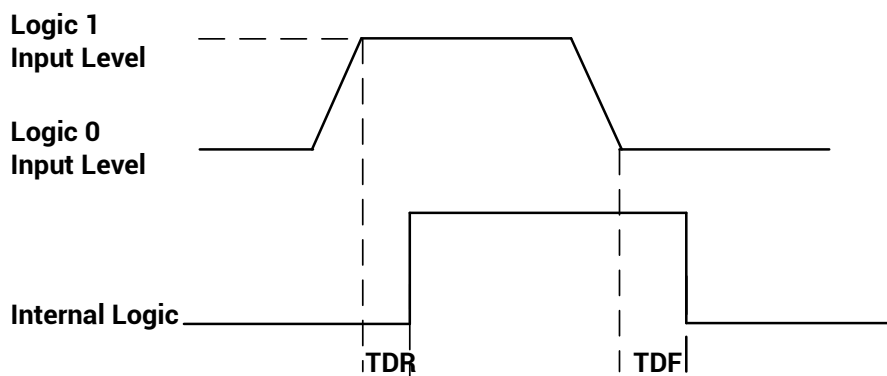

Figure 8-2 Input Logic Level

When the external voltage is 12 VDC and the external pull-up resistor is 1 KΩ, the electrical features of opto-isolated input is shown below.

Table 8-1 Input Electrical Feature

Parameter Name	Parameter Symbol	Value
Input Logic Level Low	VL	0 VDC to 1 VDC
Input Logic Level High	VH	3.3 VDC to 24 VDC
Input Rising Delay	TDR	1.28 μs to 2.04 μs
Input Falling Delay	TDF	25.6 μs to 28 μs

When the external voltage is 24 VDC and the external pull-up resistor is 4.7 KΩ, the electrical features of opto-isolated input is shown below.

Table 8-2 Input Electrical Feature

Parameter Name	Parameter Symbol	Value
Input Logic Level Low	VL	0 VDC to 1 VDC
Input Logic Level High	VH	3.3 VDC to 24 VDC
Input Rising Delay	TDR	2.32 μs to 3.08 μs
Input Falling Delay	TDF	22.6 μs to 27.2 μs

8.1.2 Output Signal

The internal circuit of opto-isolated output (Line 1) is as follows.

Note

The maximum output current of Line 1 is 25 mA.

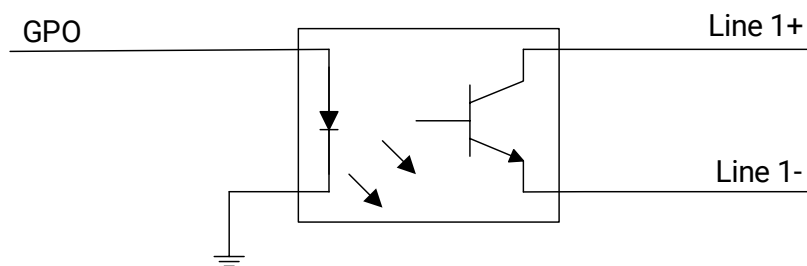

Figure 8-3 Internal Circuit of Output Signal

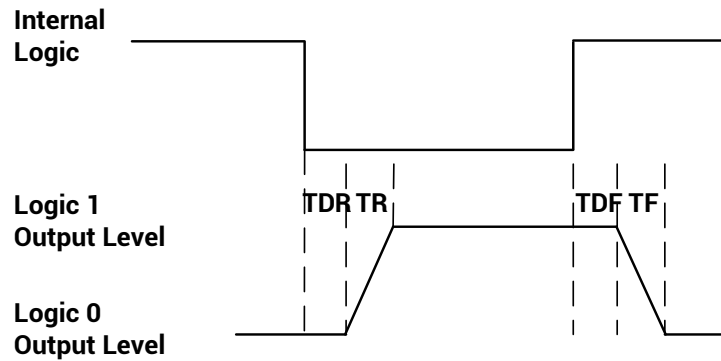

Figure 8-4 Output Logic Level

When the external voltage is 12 VDC and the external pull-up resistor is 1 KΩ, the electrical features of opto-isolated output is shown below.

Table 8-3 Output Electrical Feature

Parameter Name	Parameter Symbol	Value
Output Logic Level Low	VL	1.1 VDC to 1.46 VDC
Output Logic Level High	VH	2.54 VDC to 11.3 VDC
Output Rising Time	TR	17.6 μs to 104 μs
Output Falling Time	TF	0.4 μs to 2 μs
Output Rising Delay	TDR	26.8 μs to 72 μs
Output Falling Delay	TDF	0.44 μs to 1.92 μs

When the external voltage is 24 VDC and the external pull-up resistor is 4.7 KΩ, the electrical features of opto-isolated output is shown below.

Table 8-4 Output Electrical Feature

Parameter Name	Parameter Symbol	Value
Output Logic Level Low	VL	0 VDC to 1.3 VDC
Output Logic Level High	VH	2.26 VDC to 22.4 VDC
Output Rising Time	TR	21.6 μs to 144 μs
Output Falling Time	TF	0.4 μs to 1.6 μs
Output Rising Delay	TDR	22.4 μs to 96 μs
Output Falling Delay	TDF	0.44 μs to 1.12 μs

With different external voltage and resistance, the corresponding current and the parameter of output logic level low are shown below.

Table 8-5 Parameters of Output Logic Level Low

External Voltage	External Resistance	VL	Output Current
3.3 VDC	1 KΩ	575 mV	2.7 mA
5 VDC	1 KΩ	840 mV	4.1 mA
12 VDC	2.4 KΩ	915 mV	4.6 mA
24 VDC	4.7 KΩ	975 mV	4.9 mA

8.1.3 Bi-Directional Signal

The device has one bi-directional I/O signal (Line 2), and you can set it as input signal or output signal according to demands. Its internal circuit is as follows.

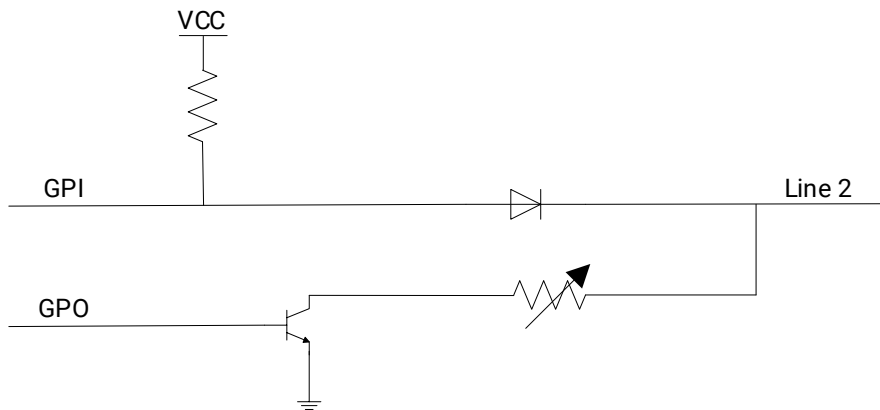

Figure 8-5 Internal Circuit of Bi-Directional Signal

Configured as Input Signal

Note

- Make sure that the input voltage is not from 1 VDC to 3.3 VDC, because the electric status between these two values are not stable.
- The breakdown voltage is 30 VDC. Keep voltage stable.
- To prevent damage to the GPIO pin, please connect GND first, and then input voltage in Line 2.

The logic level and electrical feature when Line 2 is configured as input are shown below.

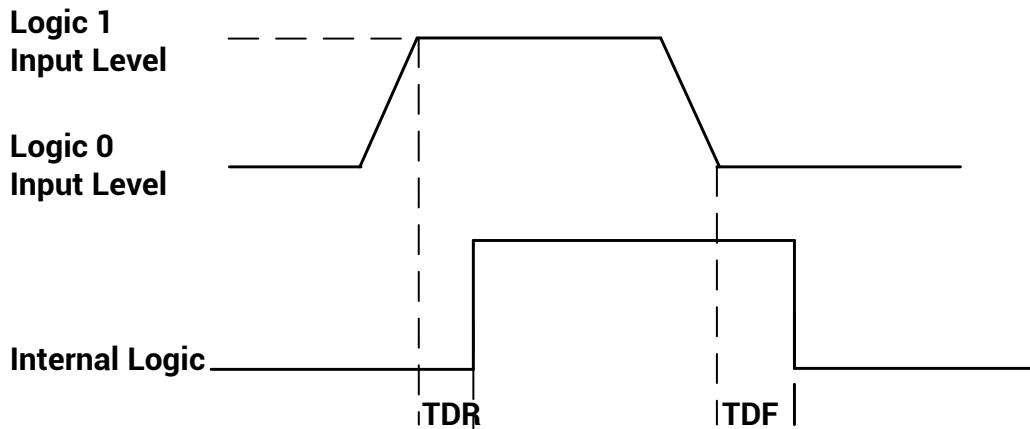

Figure 8-6 Input Logic Level

When the external voltage is 12 VDC and the external pull-up resistor is 1 K Ω , the electrical features of input is shown below.

Table 8-6 Input Electrical Feature

Parameter Name	Parameter Symbol	Value
Input Logic Level Low	VL	0 VDC to 1 VDC
Input Logic Level High	VH	3.3 VDC to 24 VDC
Input Rising Delay	TDR	1.28 μ s to 2.04 μ s
Input Falling Delay	TDF	25.6 μ s to 28 μ s

When the external voltage is 24 VDC and the external pull-up resistor is 4.7 K Ω , the electrical features of input is shown below.

Table 8-7 Input Electrical Feature

Parameter Name	Parameter Symbol	Value
Input Logic Level Low	VL	0 VDC to 1 VDC
Input Logic Level High	VH	3.3 VDC to 24 VDC
Input Rising Delay	TDR	2.32 μ s to 3.08 μ s
Input Falling Delay	TDF	22.6 μ s to 27.2 μ s

Configured as Output Signal

Note

The maximum current is 25 mA and the output impedance is 40 Ω .

The relation among external voltage, resistance, and the output level low is shown below.

Table 8-8 Parameters of Output Logic Level Low

External Voltage	External Resistance	VL (GPIO2)
3.3 VDC	1 KΩ	160 mV
5 VDC	1 KΩ	220 mV
12 VDC	1 KΩ	460 mV
24 VDC	1 KΩ	860 mV
30 VDC	1 KΩ	970 mV

The logic level and electrical feature when Line 2 is configured as output are shown below.

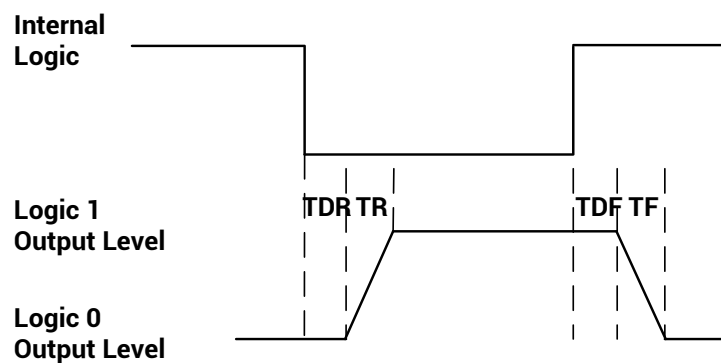

Figure 8-7 Output Logic Level

When the external voltage is 12 VDC and the external pull-up resistor is 1 KΩ, the electrical features of output is shown below.

Table 8-9 Output Electrical Feature

Parameter Name	Parameter Symbol	Value
Output Logic Level Low	VL	0 VDC
Output Logic Level High	VH	7.8 VDC to 11.8 VDC
Output Rising Time	TR	0.46 μs to 0.9 μs
Output Falling Time	TF	42 ns to 70 ns
Output Rising Delay	TDR	500 ns to 600 ns
Output Falling Delay	TDF	24 ns to 42 ns

When the external voltage is 24 VDC and the external pull-up resistor is 4.7 K Ω , the electrical features of output is shown below.

Table 8-10 Output Electrical Feature

Parameter Name	Parameter Symbol	Value
Output Logic Level Low	VL	0 VDC to 0.2 VDC
Output Logic Level High	VH	5 VDC to 23.2 VDC
Output Rising Time	TR	0.44 μ s to 4.48 μ s
Output Falling Time	TF	34 ns to 88 ns
Output Rising Delay	TDR	0.54 ns to 1.52 ns
Output Falling Delay	TDF	34 ns to 232 ns

8.1.4 Factors Affecting Transmission Delay of I/O Lines

The factors that affect the transmission delay of I/O lines are shown below, where ★ represents the main influencing factor and ☆ represents the secondary factor.

Table 8-11 Factors Affecting Transmission Delay of I/O Lines

Lines Factors	Opto-Isolated Input Lines	GPIO Input Lines	Opto-Isolated Output Lines	GPIO Output Lines
Working Temperature	★	☆	★	☆
Production Differences of Electronic Components	★	☆	★	☆
Aging	★	-	★	-
External I/O Power Supply Voltage	★	-	★	☆
Load Resistance	-	-	★	☆
Load Current	-	-	★	☆

Regarding the factors that affect the transmission delay of I/O lines in the table above, we provide the following explanations and suggestions:

- Use the I/O circuit at the recommended working temperature of the device. See the device's datasheet for the working temperature.
- Applying current to the input and output circuits of the opto-coupler will accelerate the aging rate of the opto-coupler. Keep the current to a minimum level, and ensure a stable transmission delay.

- In order to reduce the low-speed transmission delay, it is recommended to use an external I/O supply voltage of about 5 V.
- For a better quick trigger, use the recommended pull-up resistor.
- Generally, the trigger input-output frequency of an opto-coupler circuit rarely exceeds 10 kHz, and the trigger input-output frequency of a GPIO circuit rarely exceeds 1 MHz. Keep the trigger input-output frequency of the circuit within this range.
- If you need to reduce the transmission delay, it is recommended to use the GPIO line, which has a shorter transmission delay than the opto-coupler delay. But the GPIO line has the risk of burning out, so please use it with caution.
- The bounce of the trigger signal may cause the internal bounce of the device to increase. To avoid bounce, keep the edge of the trigger signal steep to reduce the internal bounce of the device (preferably less than 1 μ s).

8.2 I/O Wiring

This section introduces how to wire the device via its I/O connector.

Note

Here we take one kind of device as an example to introduce I/O wiring. The appearance here is for reference only, and the actual device you purchased shall prevail.

8.2.1 Input Signal Wiring

The input signal wiring is shown below when the device uses Line 0 as trigger source in external trigger mode.

Note

Input signal wiring may differ by the external device type.

PNP Device

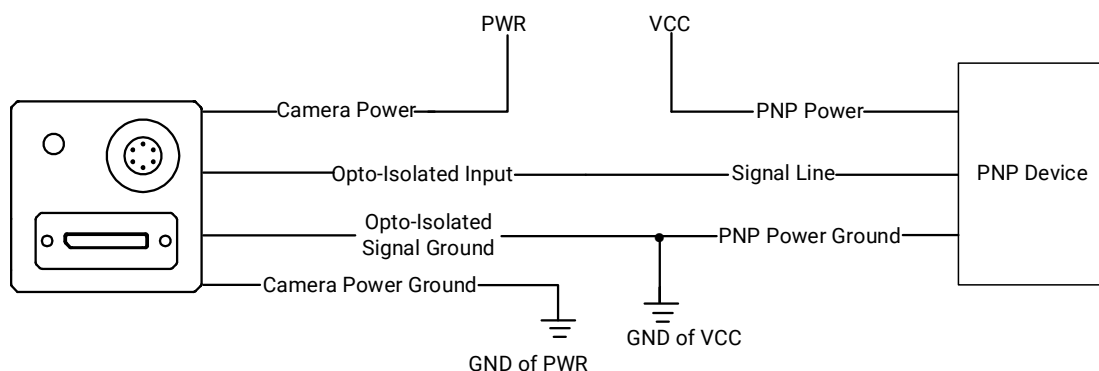

Figure 8-8 Input Signal Connects to PNP Device

NPN Device

- If the VCC of NPN device is 24 VDC, it is recommended to use a 4.7 K Ω pull-up resistor.
- If the VCC of NPN device is 12 VDC, it is recommended to use a 1 K Ω pull-up resistor.

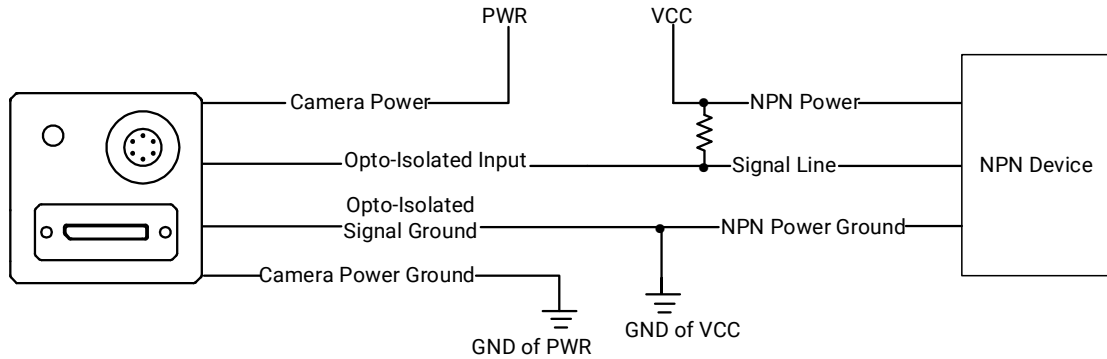

Figure 8-9 Input Signal Connects to NPN Device

Switch

If the VCC of switch is 24 VDC, it is recommended to connect a 4.7 K Ω resistor in series with the switch to protect circuit.

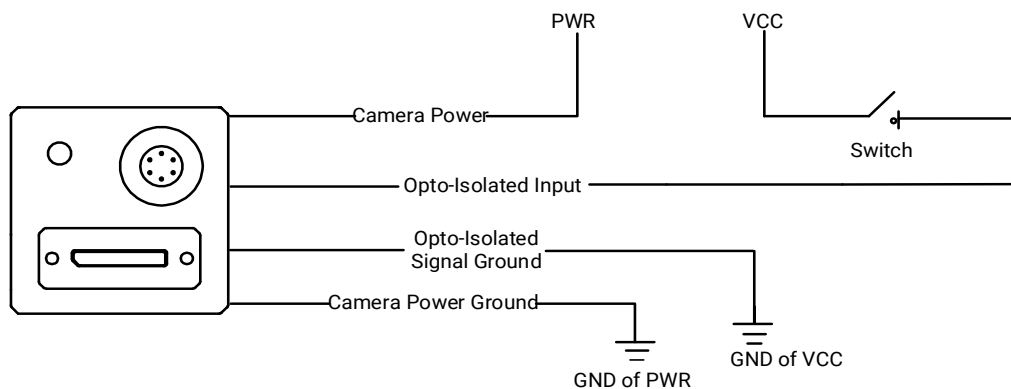

Figure 8-10 Input Signal Connects to Switch

8.2.2 Output Signal Wiring

The output signal wiring is shown below when the device uses Line 1 as the output signal.

Note

Output signal wiring may differ by the external device type.

PNP Device

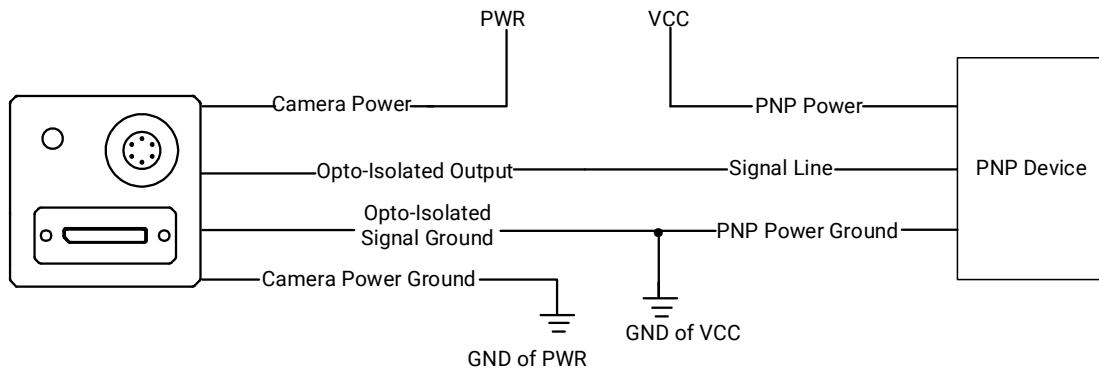

Figure 8-11 Output Signal Connects to PNP Device

NPN Device

- If the VCC of NPN device is 24 VDC, it is recommended to use a 4.7 K Ω pull-up resistor.
- If the VCC of NPN device is 12 VDC, it is recommended to use a 1 K Ω pull-up resistor.

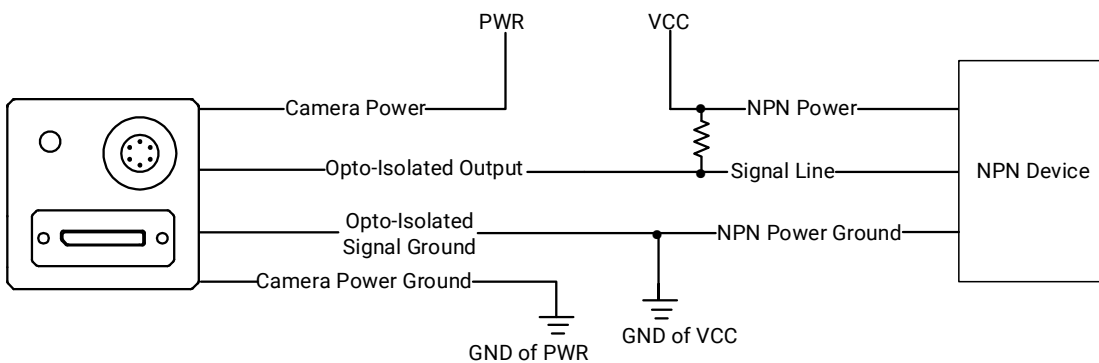

Figure 8-12 Output Signal Connects to NPN Device

8.2.3 Bi-Directional Signal Wiring

The device's Line 2 can be used as input signal and output signal.

Configured as Input Signal

The input signal wiring is shown below when the device's Line 2 is configured as the input signal.

Note

Input signal wiring may differ by the external device type.

PNP Device

It is recommended to use a 330 Ω pull-down resistor.

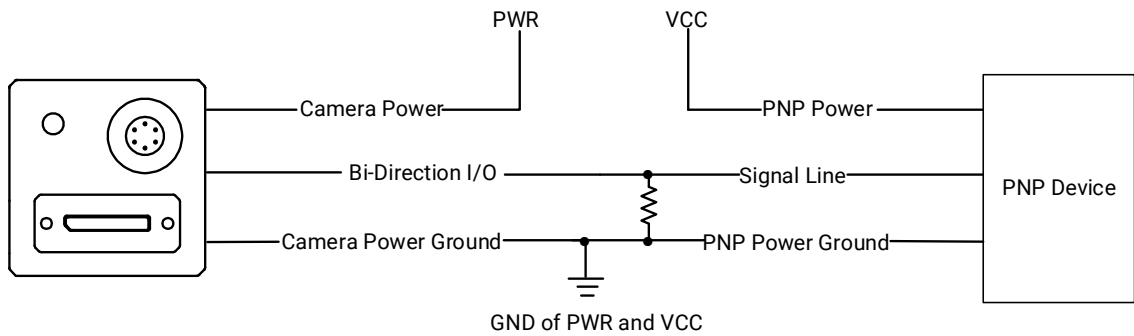

Figure 8-13 Input Signal Connects to PNP Device

Note

When connecting to PNP device, it is not recommended to use Line 2 as the input, which will cause the device to overheat severely. Line 0 as the input is recommended.

NPN Device

- If the VCC of NPN device is 24 VDC, it is recommended to use a 4.7 K Ω pull-up resistor.
- If the VCC of NPN device is 12 VDC, it is recommended to use a 1 K Ω pull-up resistor.

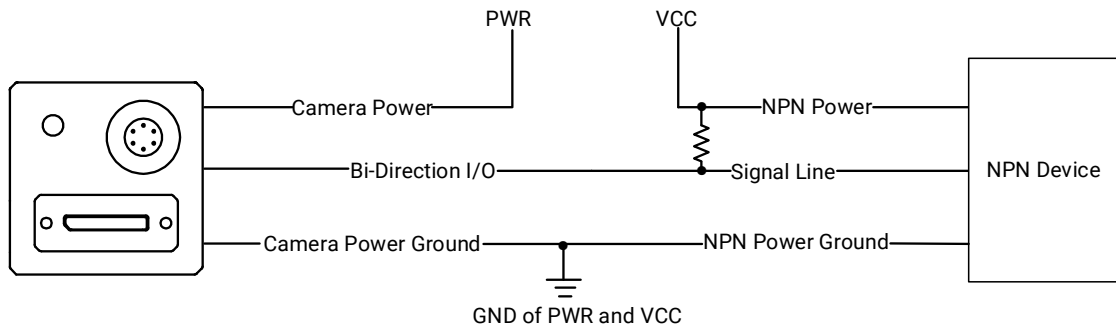

Figure 8-14 Input Signal Connects to NPN Device

Switch

The switch value can provide low electrical level to trigger Line 2.

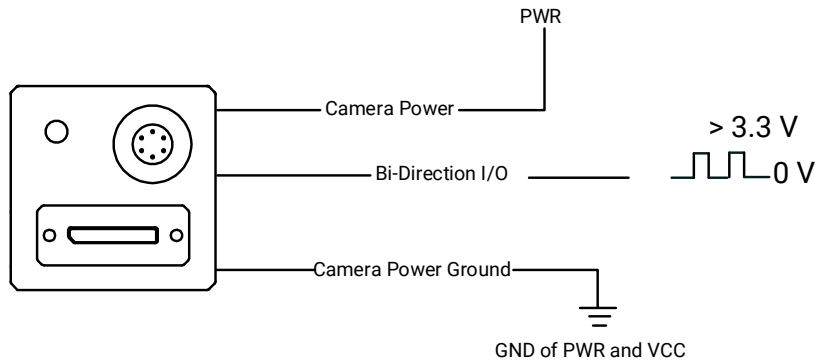

Figure 8-15 Input Signal Connects to Switch

Configured as Output Signal

The output signal wiring is shown below when the device's Line 2 is configured as the output signal.

Note

Output signal wiring may differ by the external device type.

PNP Device

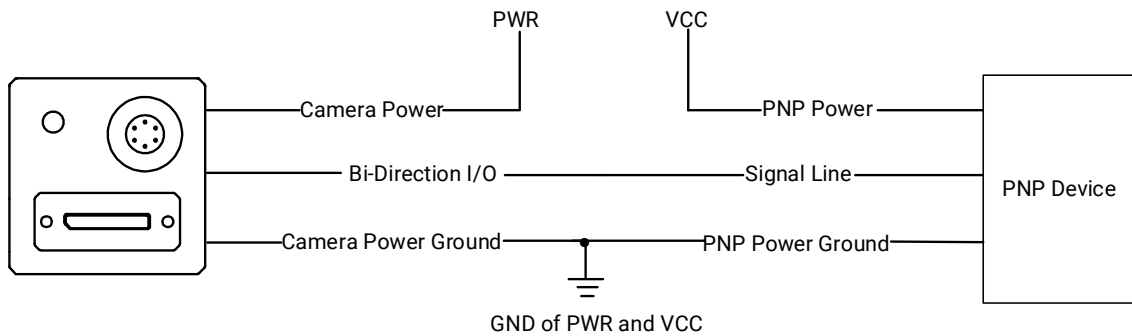

Figure 8-16 Output Signal Connects to PNP Device

NPN Device

- If the VCC of NPN device is 24 VDC, it is recommended to use a 4.7 KΩ pull-up resistor.
- If the VCC of NPN device is 12 VDC, it is recommended to use a 1 KΩ pull-up resistor.

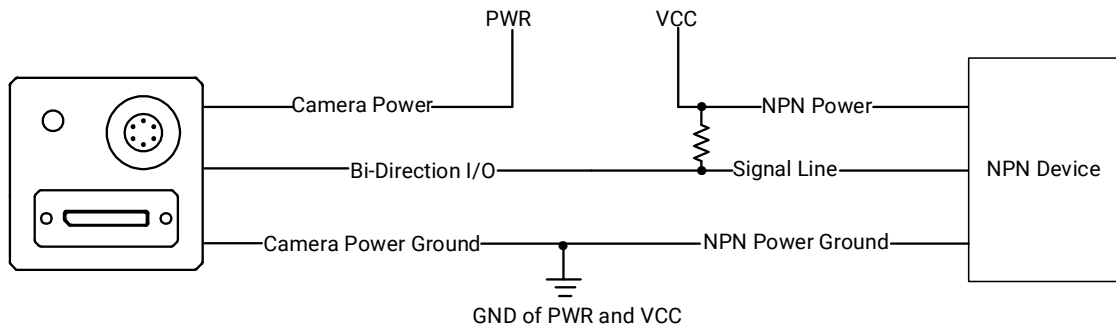

Figure 8-17 Output Signal Connects to NPN Device

Chapter 9 Trigger Input and Output

9.1 Trigger Input

9.1.1 Set Trigger Mode

The device supports 2 types of trigger modes, including internal trigger mode and external trigger mode.

- **Internal Trigger Mode:** In this mode, the device acquires images via its internal signals.
- **External Trigger Mode:** In this mode, the device acquires images via external signals like software signal and hardware signal. The trigger source of external trigger mode includes software trigger, hardware trigger, counter trigger, and anyway mode.

Enable Internal Trigger Mode

Go to **Acquisition Control** → **Trigger Mode**, and select **Off** as **Trigger Mode**.

 **Note**

Off refers to the internal trigger mode.

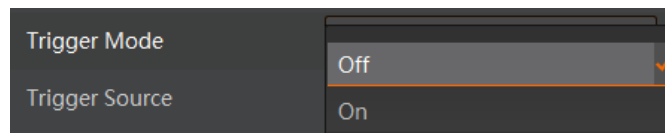

Figure 9-1 Enable Internal Trigger Mode

Enable External Trigger Mode

Go to **Acquisition Control** → **Trigger Mode**, and select **On** as **Trigger Mode**.

 **Note**

On refers to the external trigger mode.

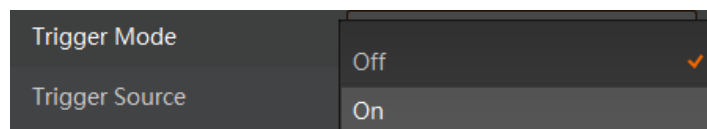

Figure 9-2 Enable External Trigger Mode

9.1.2 Set Trigger Source

External Trigger Source

The device's external trigger source includes software trigger, hardware trigger, counter trigger, link trigger, and anyway mode. Go to **Acquisition Control** → **Trigger Source**, and select **Trigger Source** according to actual demands.

Table 9-1 Trigger Source Description

External Trigger Source	Parameter	Description
Software Trigger	Software	The software sends trigger signal to the device via Gigabit Ethernet to acquire images.
Hardware Trigger	Line 0, Line 2	External device connects to the device via device I/O interface. External device sends trigger signal to device to acquire images.
Counter Trigger	Counter 0	The counter sends trigger signal to the device to acquire images.
Anyway	Anyway	The device can receive software trigger, and hardware trigger to acquire images.

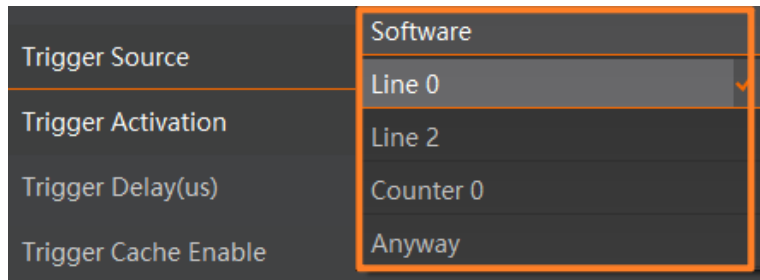

Figure 9-3 External Trigger Source

Note

These four external trigger sources are valid only when the **Trigger Mode** is **On**.

Set and Execute Software Trigger

In software trigger, the software sends trigger signal to the device via Gigabit Ethernet to acquire images.

Steps

1. Go to **Acquisition Control** → **Trigger Mode**, and select **On** as **Trigger Mode**.
2. Select **Software** as **Trigger Source**.

3. Click **Execute** in **Trigger Software**.

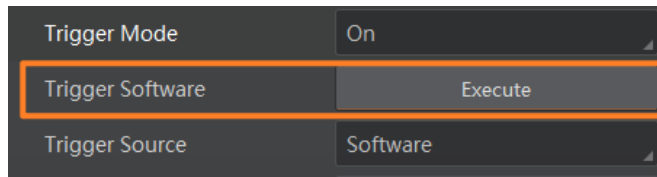

Figure 9-4 Set and Execute Software Trigger

 **Note**

Refer to section [Set Trigger Related Parameters](#) for parameters that can be configured in the trigger source, including acquisition burst frame count, trigger delay, and trigger cache.

Set and Execute Hardware Trigger

In hardware trigger, external device sends trigger signal to the device to acquire images via I/O connector.

Steps

1. Go to **Acquisition Control** → **Trigger Mode**, and select **On** as **Trigger Mode**.
2. Select **Line 0** or **Line 2** as **Trigger Source** according to actual demands.

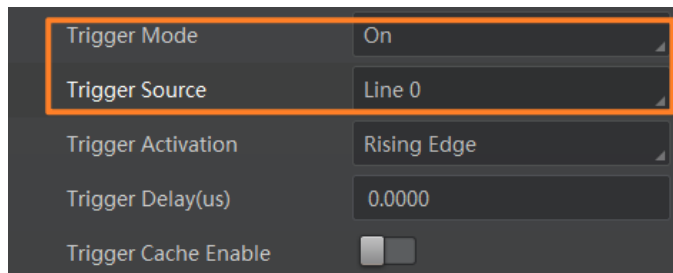

Figure 9-5 Set Line 0 or Line 2 as Input Signal

The device has one opto-isolated input (Line 0), and one bi-directional I/O (Line 2) that can be configured as input signal. Make sure that Line 2 is input signal if you want to use it as trigger source.

Steps

1. Go to **Digital IO Control** and select **Line 2** as **Line Selector**.
2. Select **Input** as **Line Mode**.

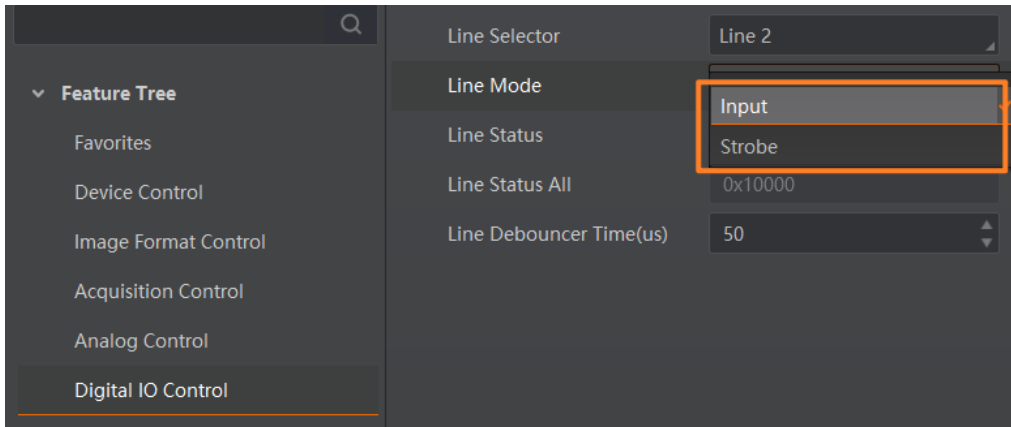

Figure 9-6 Set Line 2 as Input Signal

Note

Refer to section [Set Trigger Related Parameters](#) for parameters that can be configured in the trigger source, including acquisition burst frame count, trigger delay, trigger cache, trigger activation, and trigger debouncer.

Set and Execute Counter Trigger

In counter trigger, the counter sends trigger signal to the device to acquire images.

Steps

1. Go to **Acquisition Control** → **Trigger Mode**, and select **On** as **Trigger Mode**.
2. Select **Counter 0** as **Trigger Source**.

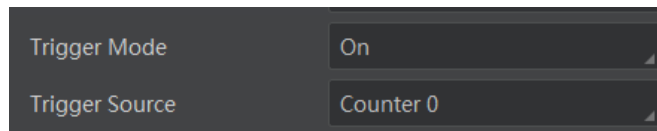

Figure 9-7 Set and Execute Counter Trigger

When using counter trigger, you need to set parameters of **Counter And Timer Control** as shown below.

Table 9-2 Parameters of Counter And Timer Control

Parameter	Read/Write	Description
Counter Selector	Read & Write	It selects counter source. Counter 0 is available only at present.
Counter Event Source	Read & Write	It selects the signal source of counter trigger. Line 0 and Line 2 are available. This parameter is disabled by default.
Counter Reset Source	Read & Write	It selects the signal source of resetting counter. Software is available only. This

Parameter	Read/Write	Description
		parameter is disabled by default.
Counter Reset	Write is available under certain condition	It resets counter and it can be executed only when Software is selected as Counter Reset Source .
Counter Value	Read & Write	It is the counter value with the range of 1 to 1023. If the parameter is set to n, the n external trigger signals can perform one counter trigger and acquire one frame of image.
Counter Current Value	Read Only	It displays the number of executed external triggers.

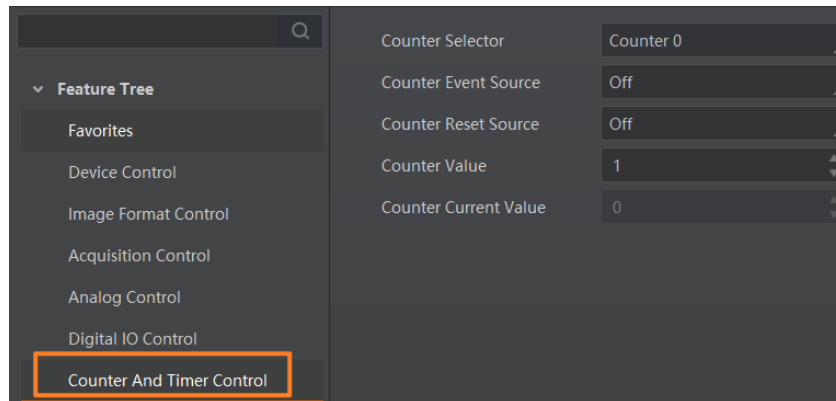

Figure 9-8 Counter And Timer Control

Note

Refer to section [Set Trigger Related Parameters](#) for parameters that can be configured in the trigger source, including acquisition burst frame count, trigger delay, trigger cache, and trigger activation.

Set and Execute Anyway Mode

In the anyway mode, the device can receive software trigger and hardware trigger to acquire images.

Steps

1. Go to **Acquisition Control** → **Trigger Mode**, and select **On** as **Trigger Mode**.
2. Select **Anyway** as **Trigger Source**.

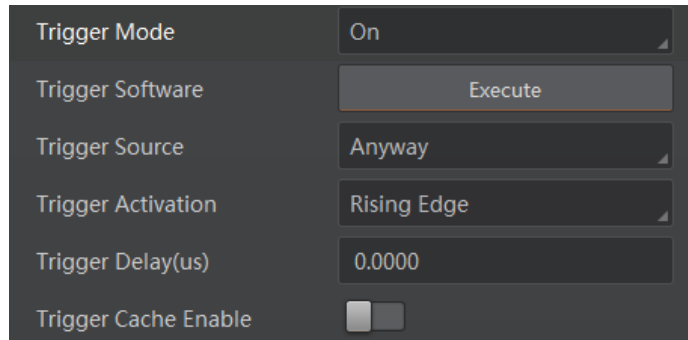

Figure 9-9 Set and Execute Anyway Mode

Note

- Refer to section [Set Trigger Related Parameters](#) for parameters that can be configured in the trigger source, including acquisition burst frame count, trigger delay, trigger cache, trigger activation, and trigger debouncer.
- The anyway mode is related to firmware program.

9.1.3 Set Trigger Related Parameters

In external trigger mode, you can set five related parameters, including acquisition burst frame count, trigger delay, trigger cache, trigger activation, and trigger debouncer.

Note

- Different trigger sources can set various parameters in external trigger mode.
- √ is supported, and × is not supported.

Table 9-3 Trigger Source and Trigger Related Parameters

Trigger Source Trigger Parameters	Software Trigger	Hardware Trigger	Counter Trigger	Anyway Mode
Acquisition Burst Frame Count	√	√	√	√
Trigger Delay	√	√	√	√
Trigger Cache	√	√	√	√
Trigger Activation	×	√	√	√
Trigger Debouncer	×	√	√	Partial support

Set Acquisition Burst Frame Count

In external trigger mode, you can set acquisition burst frame count. Go to **Acquisition Control** → **Acquisition Burst Frame Count**, and enter **Acquisition Burst Frame Count** according to actual demands.

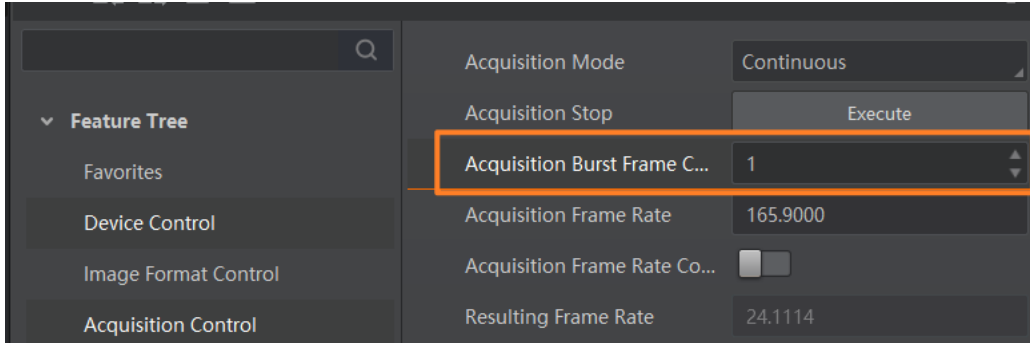

Figure 9-10 Set Acquisition Burst Frame Count

Note

- The range of **Acquisition Burst Frame Count** is from 1 to 1023.
- If **Acquisition Burst Frame Count** is 1, the device is in single frame trigger mode. If **Acquisition Burst Frame Count** is larger than 1, the device is in multi-frame trigger mode.
- If **Acquisition Burst Frame Count** is n, when input 1 trigger signal to the device, the device stops acquiring images after exposing n times and outputting n frame images.
- The sequence diagram below uses rising edge as trigger activation.



Figure 9-11 Sequence Diagram of Acquisition Burst Frame Count

Set Trigger Delay

The trigger delay function allows the device to add a delay between the receipt of trigger signal and the moment the trigger becomes active. Go to **Acquisition Control** → **Trigger Delay**, and enter **Trigger Delay**. The value should be between 0 and 16000000, and the unit is μs .

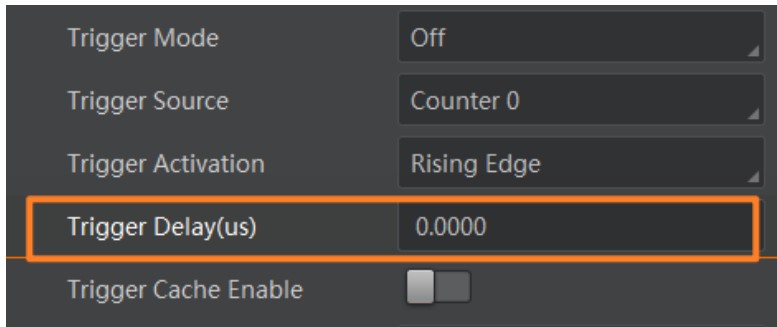

Figure 9-12 Set Trigger Delay

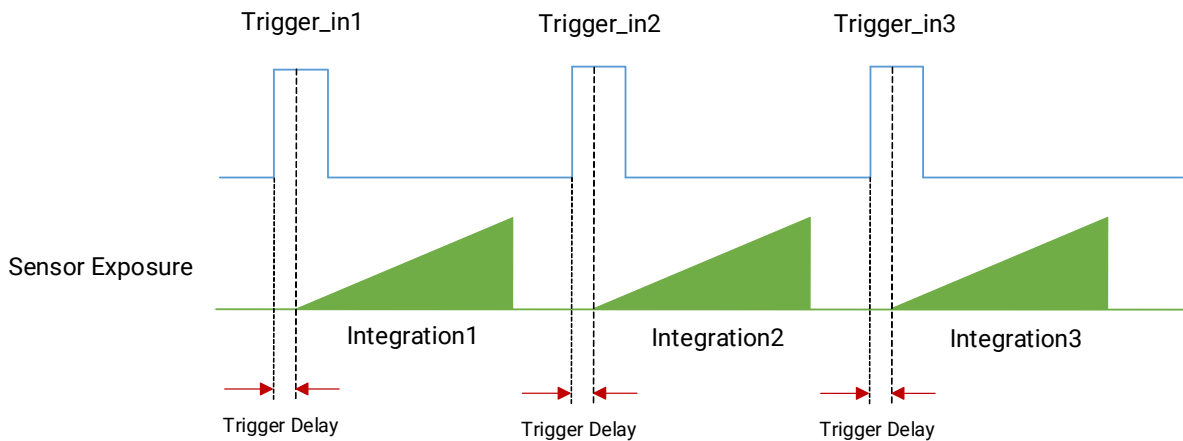

Figure 9-13 Sequence Diagram of Trigger Delay

Note

The sequence diagram above uses rising edge as trigger activation.

Set Trigger Cache

The trigger cache function allows the device to save and process new signal during trigger stage, and the device can save and process three trigger signals at most. Go to **Acquisition Control** → **Trigger Cache Enable**, and enable **Trigger Cache Enable**.

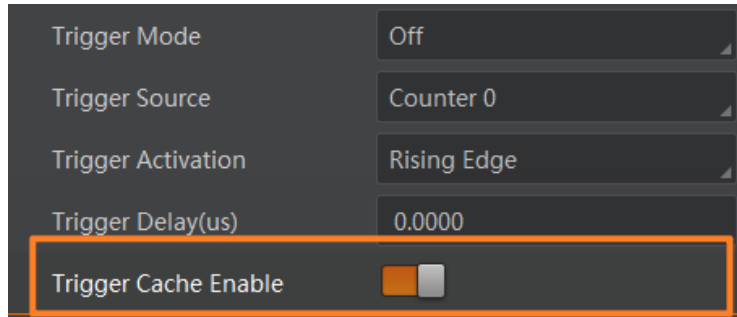

Figure 9-14 Set Trigger Cache

For example, if the device receives the 2nd trigger signal when it is processing the 1st trigger signal, and the result will be different depending on whether **Trigger Cache Enable** is enabled or not.

- The 2nd trigger signal will be filtered without processing if **Trigger Cache Enable** is disabled.

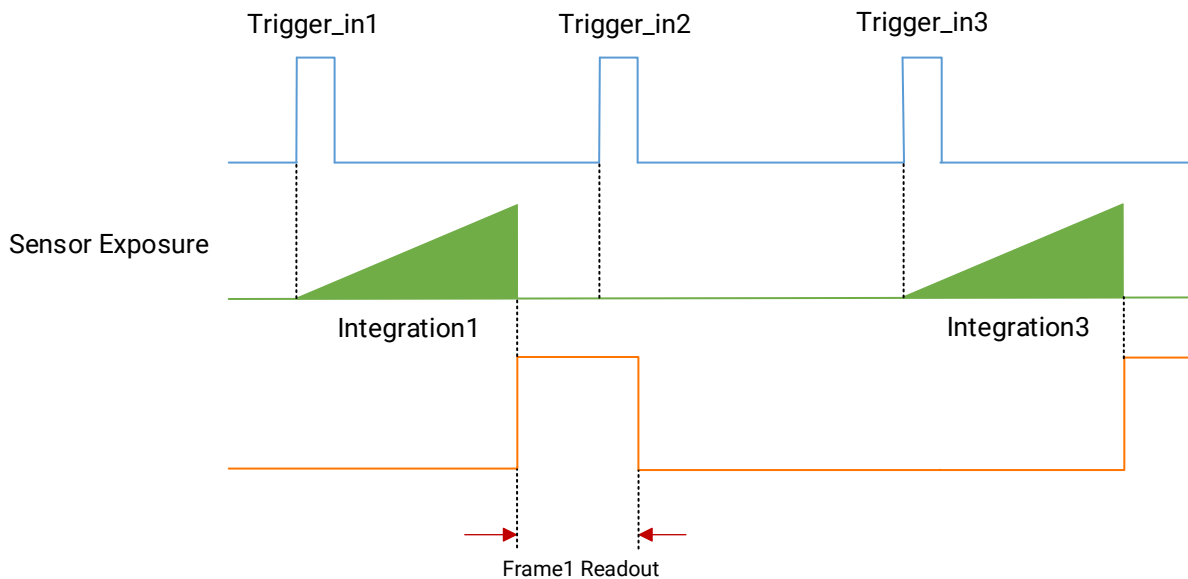

Figure 9-15 Second Frame Filtered

- The 2nd trigger signal will be saved if **Trigger Cache Enable** is enabled.

If the 1st frame image's exposure time of the 2nd trigger signal is not earlier than the device's last frame creation time of the 1st trigger signal, and then the 2nd trigger signal's 1st frame image is created normally.

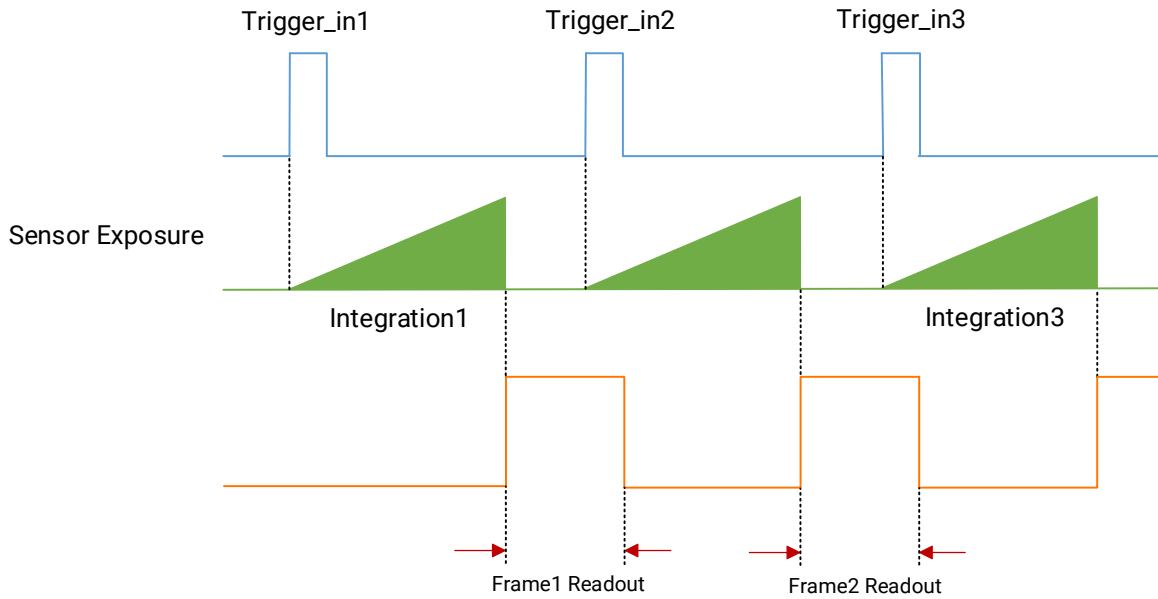

Figure 9-16 Second Frame Created Normally

If the 1st frame image's exposure time of the 2nd trigger signal is earlier than the device's last frame creation time of the 1st trigger signal, and then the device will delay this exposure time. Thus making sure this exposure time is not earlier than the device's last frame creation time of the 1st trigger signal.

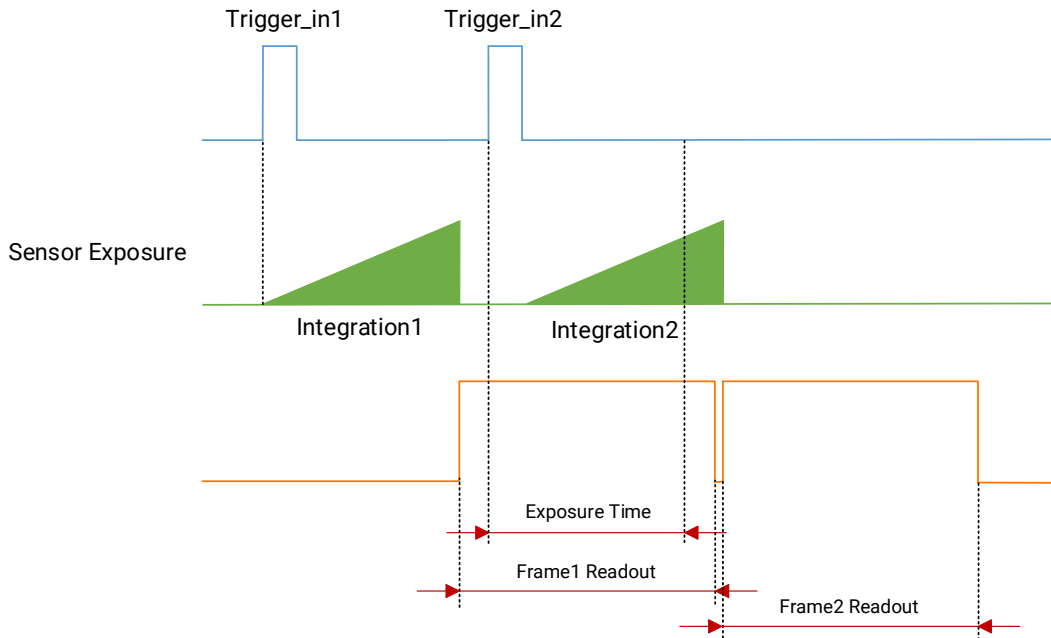

Figure 9-17 Sequence Diagram

 **Note**

The three sequence diagrams above use rising edge as trigger activation.

Set Trigger Activation

The device supports triggering image acquisition in the rising edge, falling edge, level high, level low or any edge of the external signal. Go to **Acquisition Control** → **Trigger Activation**, and select **Rising Edge**, **Falling Edge**, **Any Edge**, **Level High**, or **Level Low** as **Trigger Activation**.

- **Rising Edge**: It means that when the level signal sent by external device is in rising edge, the device receives trigger signal and starts to acquire images.
- **Falling Edge**: It means that when the level signal sent by external device is in falling edge, the device receives trigger signal and starts to acquire images.
- **Any Edge**: It means that when the level signal sent by external device is in rising or falling edge, the device receives trigger signal and starts to acquire images.
- **Level High**: The level high of the trigger signal is valid. As long as the trigger signal is in level high, the device is in image acquisition status.
- **Level Low**: The level low of the trigger signal is valid. As long as the trigger signal is in level low, the device is in image acquisition status.

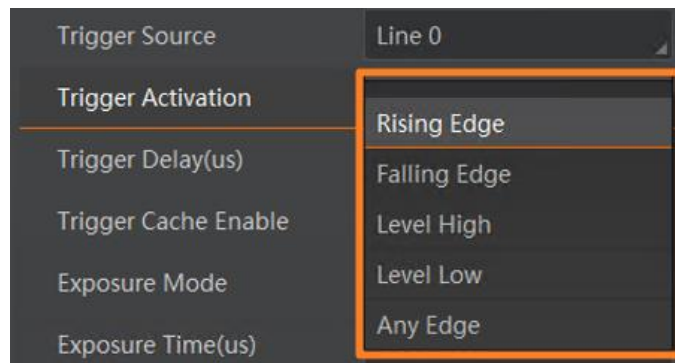

Figure 9-18 Set Trigger Activation

 **Note**

The trigger activation mode may differ by the trigger mode.

Set Trigger Debouncer

The trigger debouncer function allows the device to filter out unwanted short external trigger signal that is input to the device.

Go to **Digital IO Control** → **Line Debouncer Time**, and enter **Line Debouncer Time** according to actual demands. The range of **Line Debouncer Time** is from 0 μ s to 1000000 μ s.

Note

If the **Line Debouncer Time** you set is greater than the time of trigger signal, this trigger signal will be ignored.

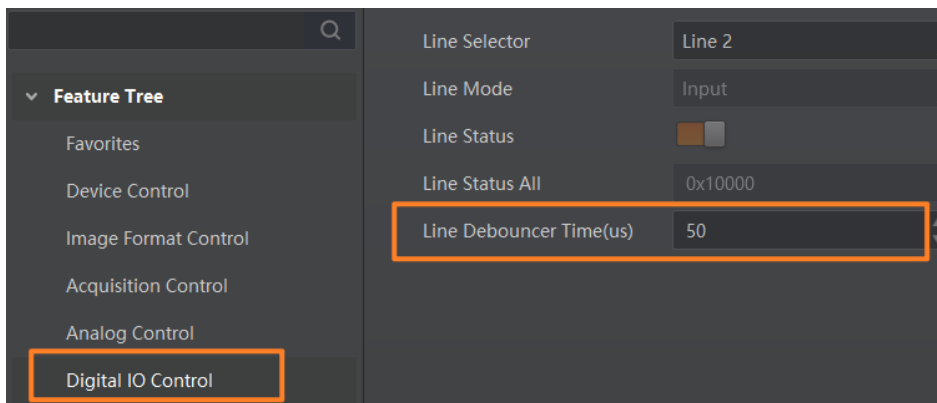

Figure 9-19 Set Trigger Debouncer

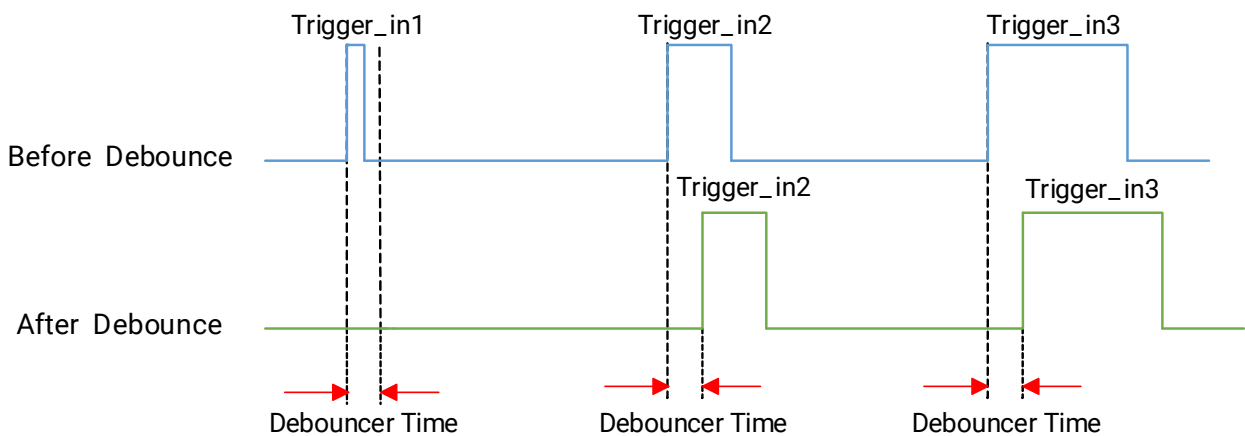

Figure 9-20 Sequence Diagram of Trigger Debouncer

Note

- The sequence diagram above uses rising edge as trigger activation.
- When you use the trigger debouncer function, there may be a delay in the signal.

9.2 Trigger Output

The device has one opto-isolated output (Line 1), and one bi-directional I/O (Line 2) that can be configured as output signal. The method of setting bi-directional configurable line as output line as follows:

Steps

1. Go to **Digital IO Control**, and select **Line 2** as **Line Selector**.
2. Set **Strobe** as **Line Mode**.

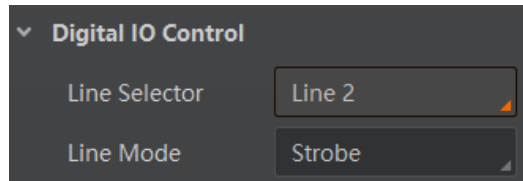

Figure 9-21 Select Output Signal

The output signal of the device is switch signal that can be used to control external devices such as light source, PLC, etc. There are two ways to set output signal, including line inverter and strobe signal.

9.2.1 Enable Line Inverter

The line inverter function allows the device to invert the electrical signal level of an I/O line. Go to **Digital IO Control** → **Line Inverter**, and enable it.

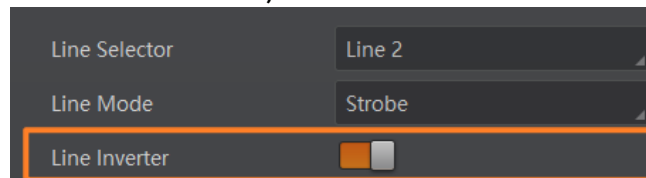

Figure 9-22 Enable Line Inverter

Note

The line inverter function is disabled by default.

9.2.2 Enable Strobe Signal

The strobe signal is used to directly output I/O signal to external devices when the device's event source occurs.

Steps

1. Go to **Digital IO Control** → **Line Source**, and select **Line Source** according to actual demands.
2. Enable **Strobe Enable**.

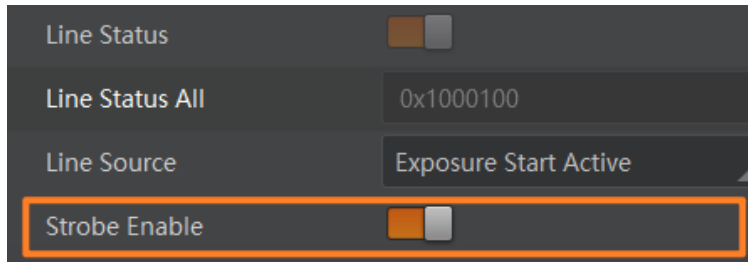

Figure 9-23 Enable Strobe Signal

The supported line sources are as follows:

Table 9-4 Line Source Description

Line Source	Description
Exposure Start Active	The device outputs signals to external devices when it starts exposure.
Exposure End Active	The device outputs signals to external devices when it stops exposure.
Acquisition Start Active	The device outputs signals to external devices when it starts acquiring images.
Acquisition Stop Active	The device outputs signals to external devices when it stops acquiring images.
Frame Burst Start Active	The device outputs signals to external devices when the device's frame burst starts.
Frame Burst End Active	The device outputs signals to external devices when the device's frame burst stops.
Frame Trigger Wait	The device is currently waiting for a frame start trigger.
Frame Start Active	The device outputs signals to external devices when it starts doing the capture of a frame.
Frame End Active	The device outputs signals to external devices when it stops doing the capture of a frame.
Soft Trigger Active	The device outputs signals to external devices when it has a software trigger.
Hard Trigger Active	The device outputs signals to external devices when it has a hardware trigger.
Counter Active	The device outputs signals to external devices when it has a counter trigger.
Timer Active	The device outputs signals to external devices when it has a timer trigger.

Note

The specific line sources may differ by device models.

If **Timer Active** is selected as **Line Source**, you can click **Execute** in **Line Trigger Software**, and enter **Strobe Line Delay** according to actual demands. The device will output signals whose duration is configured in **Strobe Line Duration**.

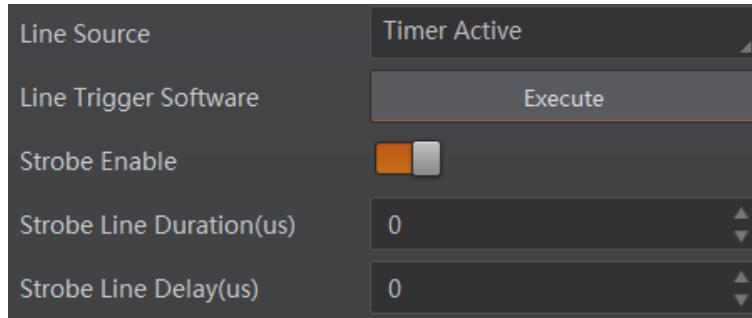

Figure 9-24 Timer Active Parameters

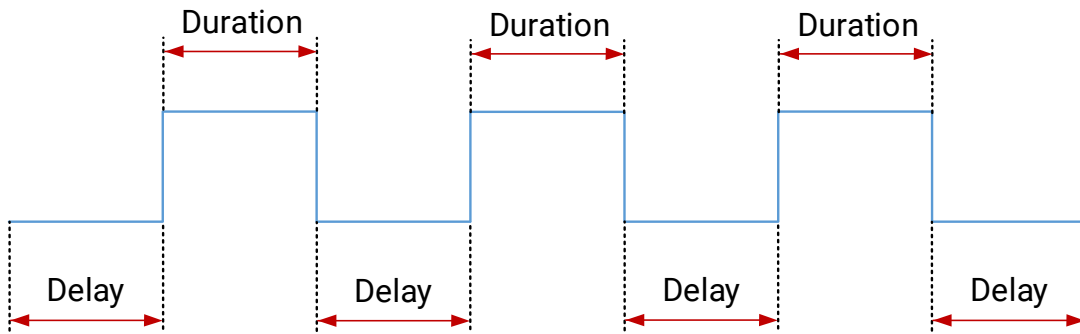

Figure 9-25 Sequence Diagram of Timer Active

Set Strobe Line Duration

After enabling strobe signal, you can set its duration. Go to **Digital IO Control** → **Strobe Line Duration**, and enter it according to actual demands.

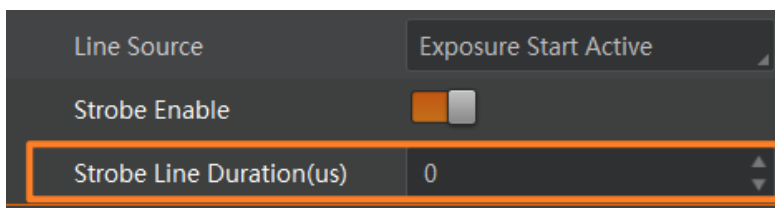

Figure 9-26 Set Strobe Line Duration

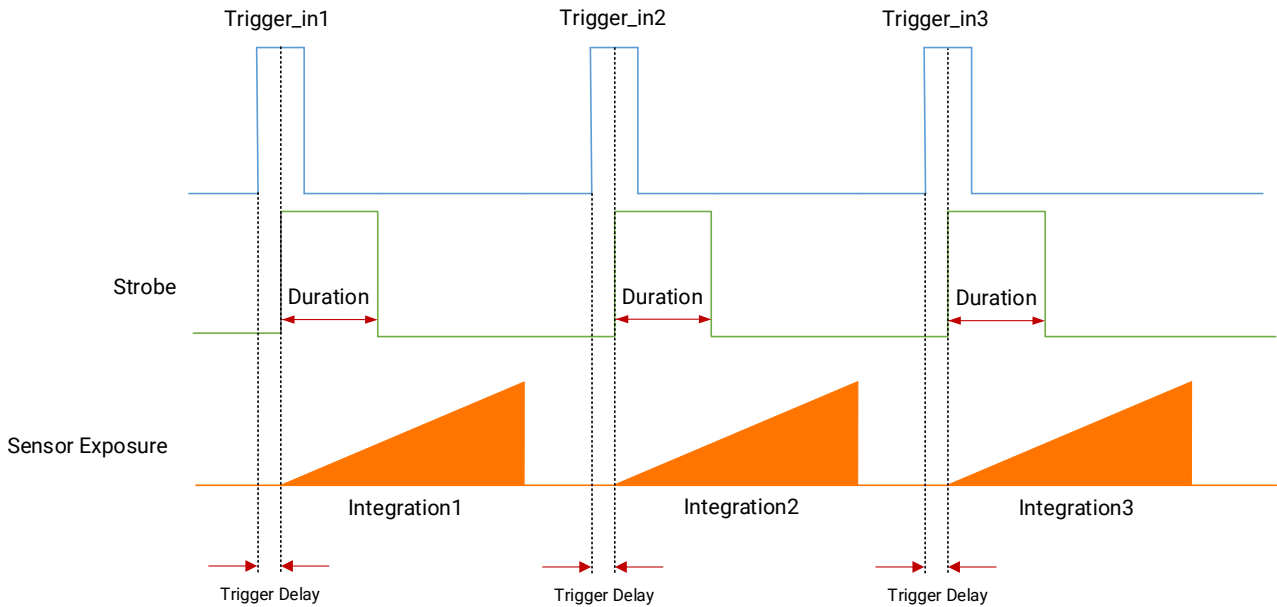

Figure 9-27 Sequence Diagram of Strobe Line Duration

Note

- When **Strobe Line Duration** value is 0, the strobe duration is equal to the exposure time.
- When **Strobe Line Duration** value is not 0, the strobe duration is the value you set.

Set Strobe Line Delay

The device supports setting strobe line delay to meet actual demands. When exposure starts, the strobe output does not take effect immediately. Instead, the strobe output will delay according to the strobe line delay settings.

Go to **Digital IO Control** → **Strobe Line Delay**, and enter it according to actual demands. The range of **Strobe Line Delay** is from 0 μ s to 10000 μ s.

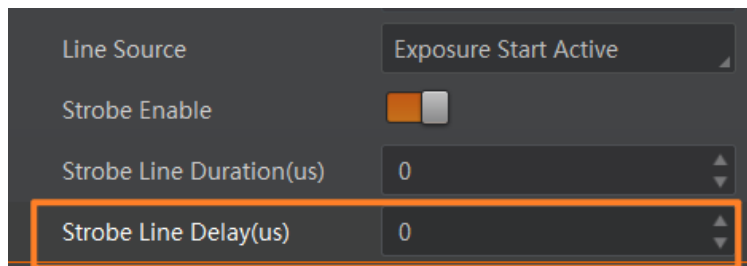

Figure 9-28 Set Strobe Line Delay

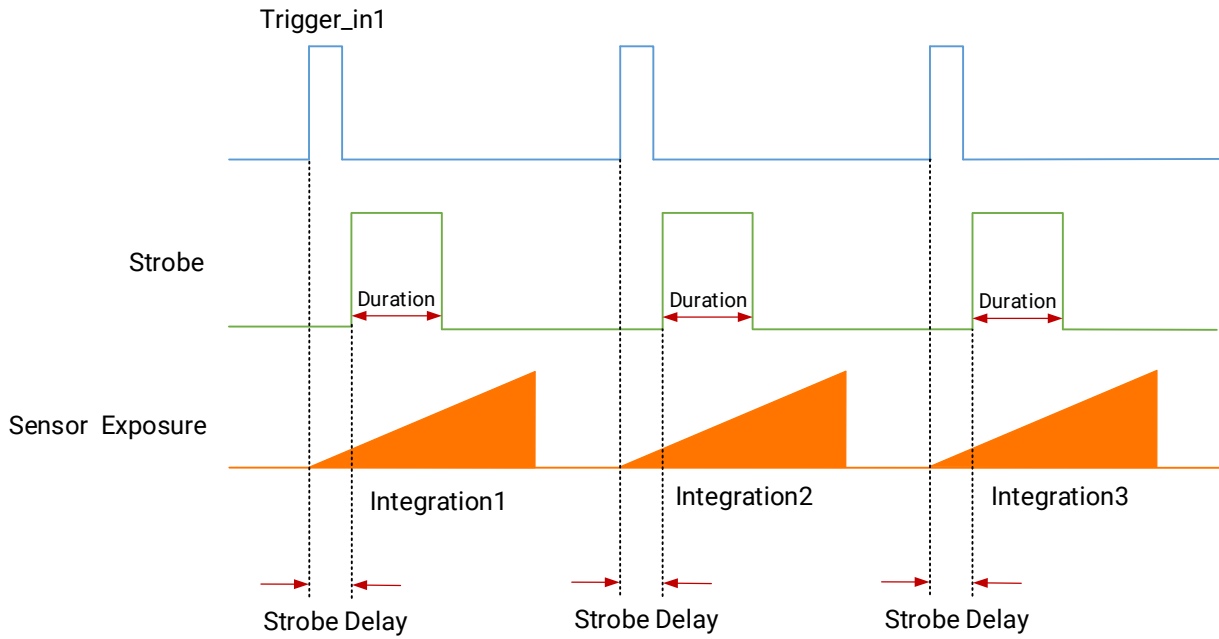

Figure 9-29 Sequence Diagram of Strobe Line Delay

Set Strobe Line Pre Delay

The device also supports the function of strobe line pre delay, which means that the strobe signal takes effect early than exposure. This function is applied to the external devices that have slow response speed.

Click **Digital IO Control** → **Strobe Line Pre Delay**, and enter **Strobe Line Pre Delay** according to actual demands. The range of **Strobe Line Pre Delay** is from 0 μ s to 5000 μ s.

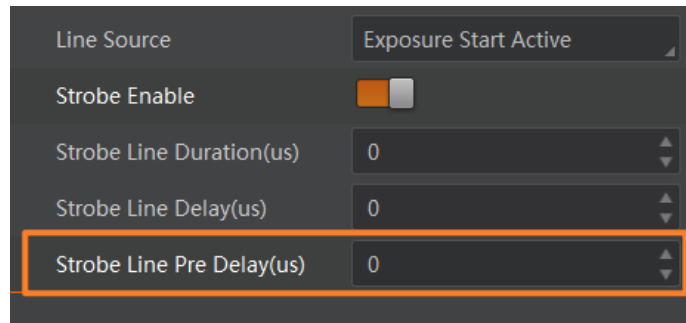

Figure 9-30 Set Strobe Pre Line Delay

The sequence diagram of strobe line pre delay is shown below.

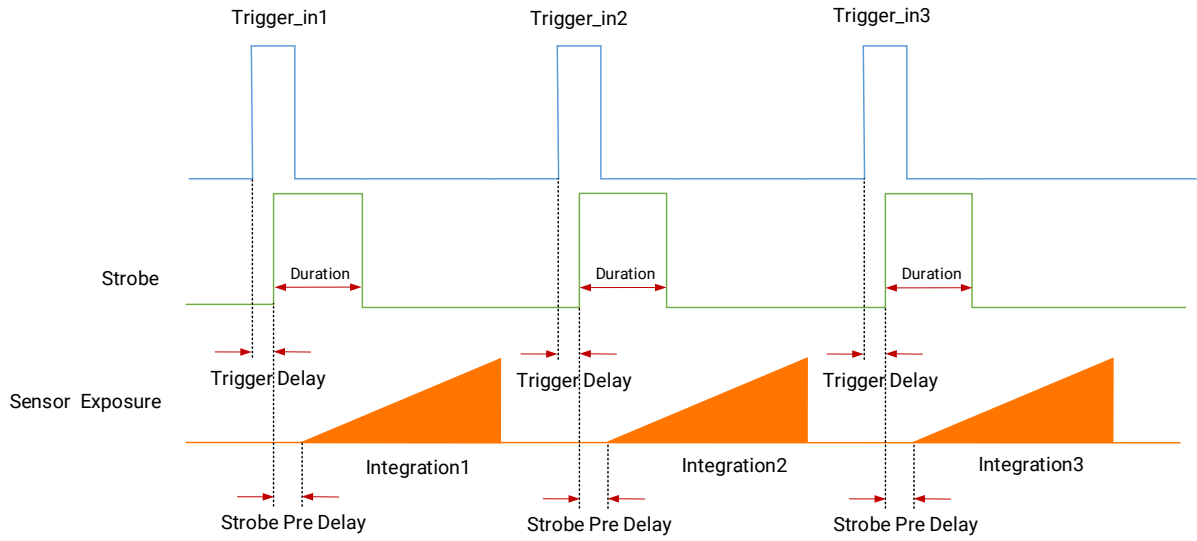

Figure 9-31 Sequence Diagram of Strobe Pre Line Delay

Chapter 10 Image Acquisition

10.1 Global Shutter and Rolling Shutter

The shutter mode of the device is divided into global shutter and rolling shutter. The shutter mode is determined by the characteristics of the sensor used by the device.

10.1.1 Global Shutter

For device that supports global shutter, its exposure starts and ends in each line simultaneously. After the exposure, data readout starts line by line. All pixels expose at the same time, and then read out at different time.

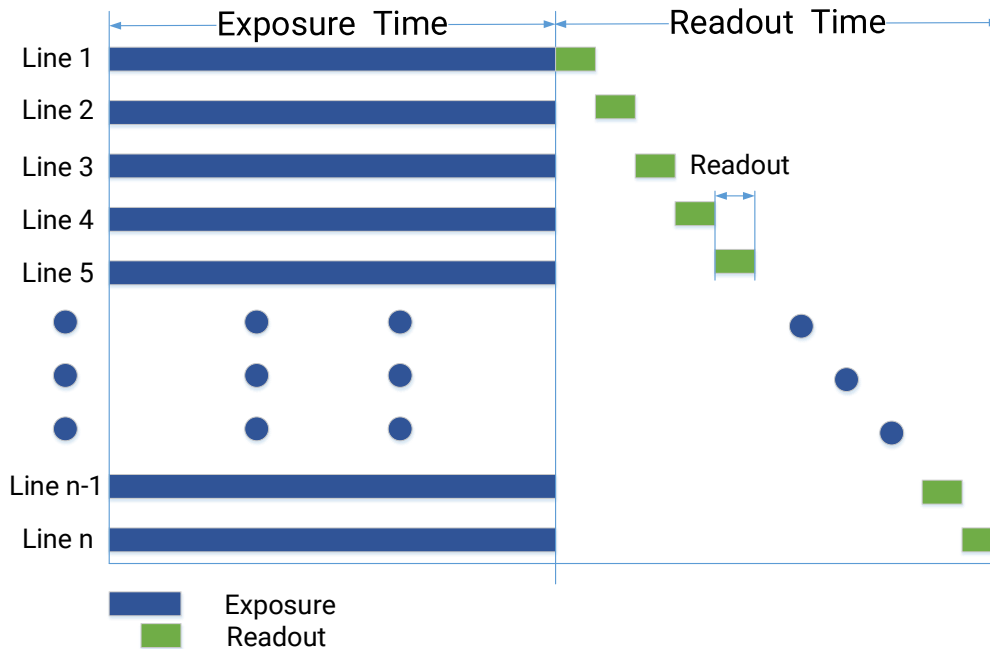

Figure 10-1 Global Shutter

10.1.2 Rolling Shutter

Working Principle

For device that supports rolling shutter, as soon as the exposure ends, the data readout starts simultaneously. After the whole action, the rest of rows start to expose and read out one by one. All pixels expose at the same time, and then read out at different time.

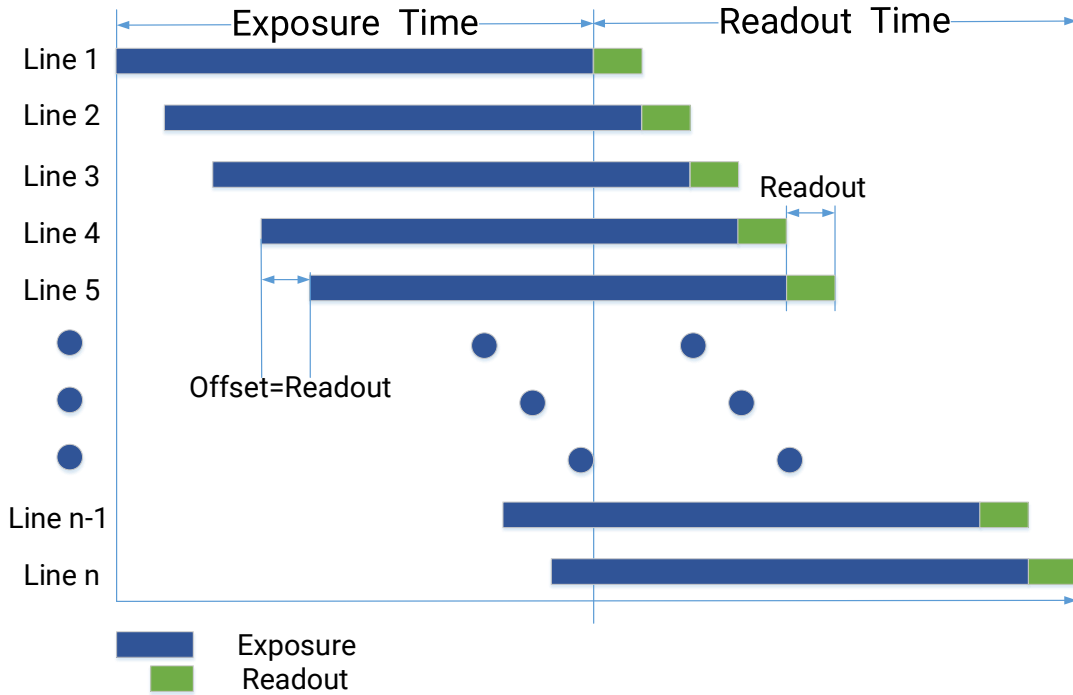

Figure 10-2 Rolling Shutter

Global Reset

Global reset means that all of the sensor's pixels start exposing at the same time, but stop exposing at different time.

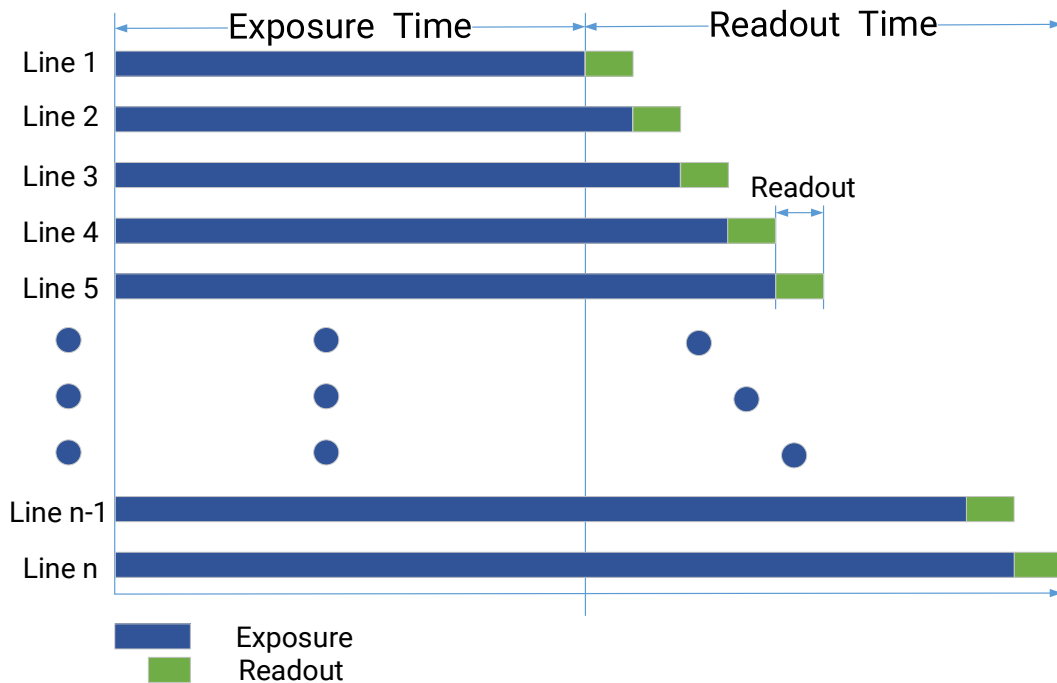

Figure 10-3 Global Reset

You can go to **Acquisition Control** → **Sensor Shutter Mode**, and select **Global Reset** as **Sensor Shutter Mode**.

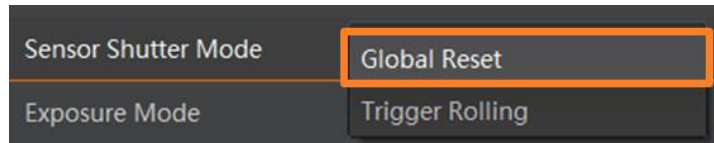

Figure 10-4 Select Global Reset

Note

- The Global Reset function may differ by device models.
 - For some device models, only when **Trigger Mode** is **On**, you can set **Sensor Shutter Mode**.
 - When Global Reset function is enabled, different exposure times for each line of the image may result in different brightness of each line. Therefore, it is recommended to use this function together with an industrial light source in a completely dark environment. By enabling the light source during the exposure time and disabling at other times, each line of the image will be illuminated equally during the same exposure time.
-

Trigger Rolling

Trigger rolling is applied to the device with rolling shutter, and this function is used to improve the max. frame rate in the trigger mode.

You can go to **Acquisition Control** → **Sensor Shutter Mode**, and select **Trigger Rolling** as **Sensor Shutter Mode**.

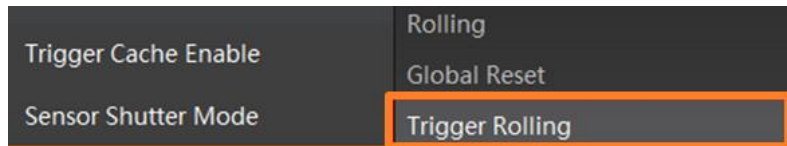

Figure 10-5 Sensor Shutter Mode

Note

- The Trigger Rolling function may differ by device models.
 - The trigger rolling does not support the overlap exposure.
-

10.2 Set Acquisition Mode

The device supports two types of acquisition modes, including **SingleFrame** mode and **Continuous** mode. Go to **Acquisition Control** → **Acquisition Mode**, and select **Continuous** or **SingleFrame** as **Acquisition Mode** according to actual demands.

- **SingleFrame**: When device starts image acquisition, it acquires one image only, and then stops.
- **Continuous**: When device starts image acquisition, it acquires images continuously. Real-time frame rate decides the acquisition frame number per second. You can stop image acquisition manually.

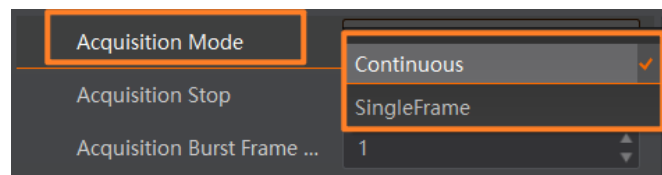

Figure 10-6 Set Acquisition Mode

10.3 Non-Overlap Exposure and Overlap Exposure

The process that the device captures one frame of image includes two stages, exposure and readout. According to the overlap relation between the exposure time and the readout time, devices with different sensors can be divided into overlap exposure and non-overlap exposure.

The device's overlap function is controlled by the overlap mode. Go to **Acquisition Control** → **Overlap Mode**, select **On** as **Overlap Mode** to have overlap exposure, and select **Off** as **Overlap Mode** to have non-overlap exposure.

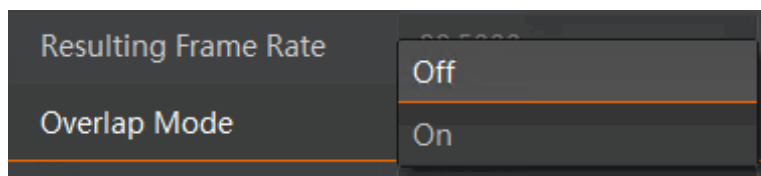

Figure 10-7 Set Overlap Mode

Note

The overlap mode function may differ by device models.

10.3.1 Non-Overlap Exposure

After completing the current frame's exposure and readout, the next frame starts to expose and read out. This process is called non-overlap exposure. The non-overlap exposure's frame period is larger than the sum of the exposure time and the readout time,

as shown below.

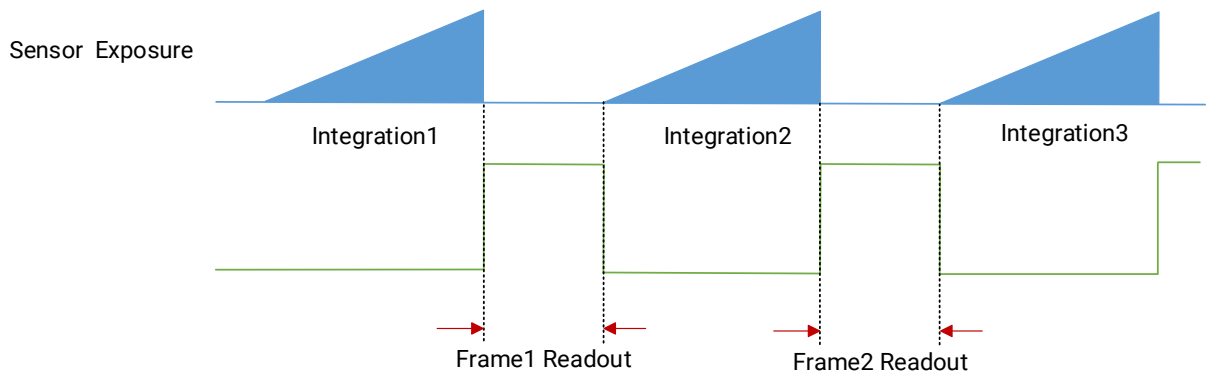

Figure 10-8 Internal Trigger Non-Overlap Exposure

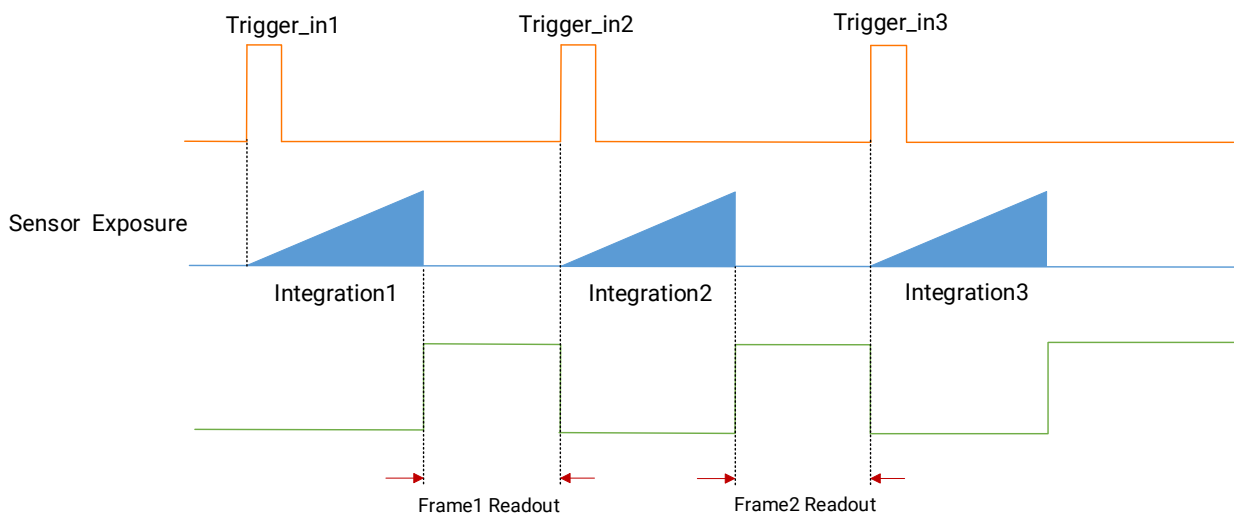

Figure 10-9 External Trigger Non-Overlap Exposure

Note

The device will ignore the external signal in the readout section under this mode.

10.3.2 Overlap Exposure

Overlap exposure refers to the overlap between the current frame exposure and the previous frame readout. In other words, when the previous frame starts to read out, the current frame starts to expose simultaneously. The overlap exposure's frame period is no greater than the sum of the exposure time and the readout time, as shown below.

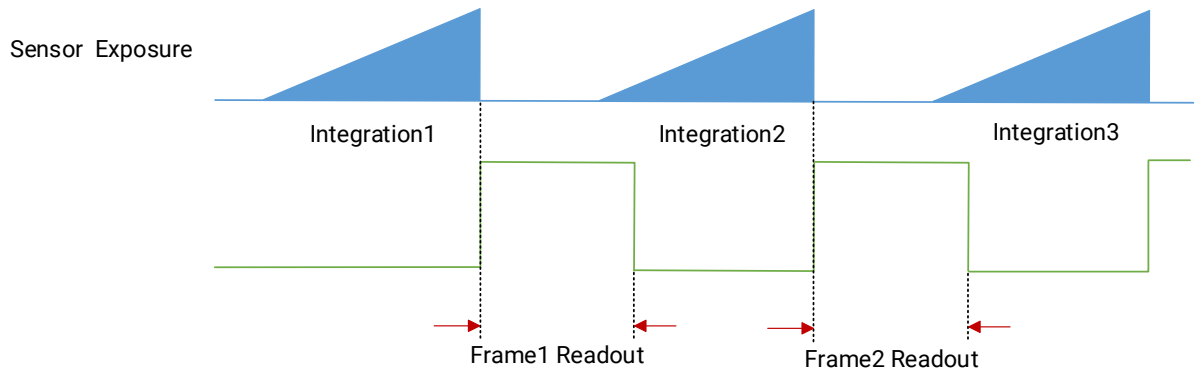

Figure 10-10 Internal Trigger Overlap Exposure

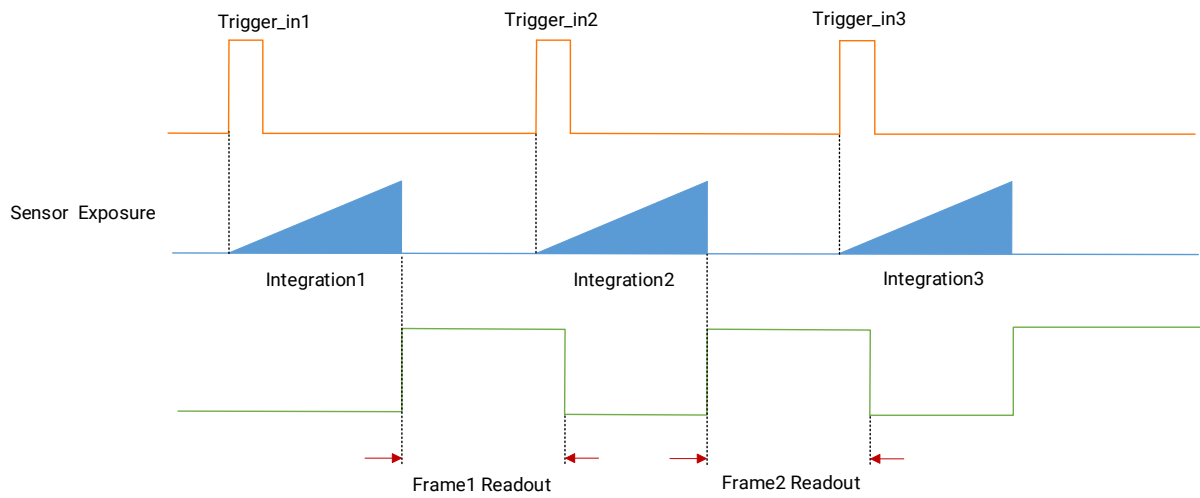

Figure 10-11 External Trigger Overlap Exposure

Note

The overlap exposure is supported in the continuous mode and trigger mode.

Chapter 11 Basic Functions

11.1 Set Frame Rate

Frame rate refers to the image quantity that is acquired by the device per second. The higher frame rate, and shorter time used for image acquisition will be. The following factors determine the device's frame rate in real-time.

- Frame readout time: The frame readout time is related with device's sensor performance and image height. The lower the image height and less the frame readout time, and the higher the frame rate will be.
- Exposure time: If the reciprocal of max. frame rate that the device supports is t , and when the configured exposure time is larger than t , the less the exposure time, the higher the frame rate will be. When the configured exposure time is less than or equal to t , exposure time will not influence the frame rate.
- Bandwidth: The larger the bandwidth, the higher the frame rate will be.
- Pixel format: The more bytes pixel format occupy, the lower the frame rate will be.
- Image compression mode: This function allows the device to compress data before transmitting to the PC, and output original image data via SDK, which can improve the frame rate to a certain extent.

Note

The image compression function may differ by the device model. Refer to section [Set Image Compression Mode](#) for details.

Steps

1. Go to **Acquisition Control** → **Acquisition Frame Rate**, and enter **Acquisition Frame Rate**.
2. Enable **Acquisition Frame Rate Control Enable**.

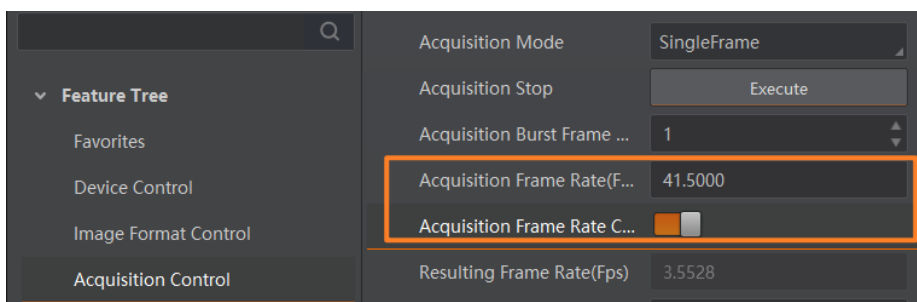

Figure 11-1 Set Frame Rate

Note

- If the real-time frame rate is smaller than the value you set, the device acquires images

by the real-time frame rate.

- If the real-time frame rate is larger than the value you set, the device acquires images by the value you set.
-

3. When the image compression mode is enabled, you can view the **Reference Frame Rate** for reference. This parameter is a reference frame rate calculated by the device based on theoretical bandwidth and compression ratio. It does not affect image output control and is displayed for reference purposes only.
4. View the device's final frame rate in **Resulting Frame Rate**.

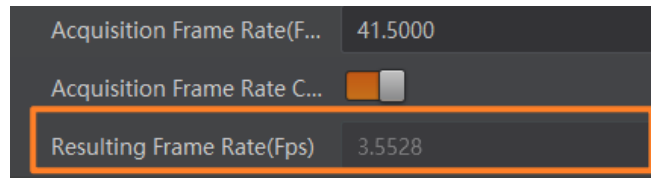

Figure 11-2 View Resulting Frame Rate

Note

- You can go to **Acquisition Control** → **Acquisition Start** / **Acquisition Stop** to start or stop image acquisition.
 - After you click **Execute** in **Acquisition Start**, some parameters cannot be edited. If you want to edit, click **Execute** in **Acquisition Stop** first.
-

11.2 Set Resolution and ROI

Note

The device displays the image with max. resolution by default.

Go to **Image Format Control**, and you can view resolution by reading **Width Max** and **Height Max**. **Width Max** stands for the max. pixels per inch in width direction, and **Height Max** stands for the max. pixels per inch in height direction.

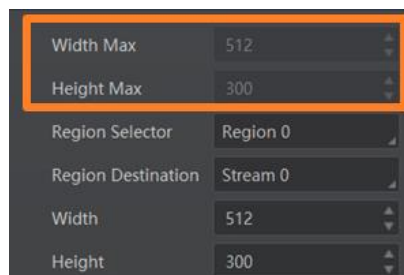

Figure 11-3 View Resolution

If you are only interested in a certain region of the image, you can set a Region of Interest (ROI) for the device.

When the user is only interested in some details in the image, image cropping is needed.

That is, an ROI setting is performed on the device to output an image of the region of interest. Setting the region of interest can reduce the transmission data bandwidth and may improve the device's frame rate to a certain extent.

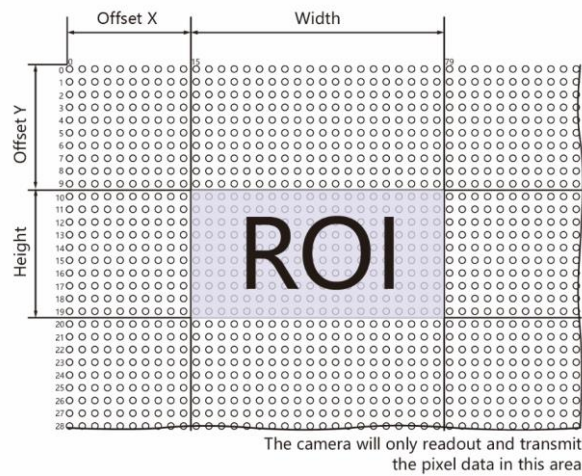

Figure 11-4 ROI

Note

- Region of interest can be set only when you stop real-time acquisition.
- The device currently supports one ROI only, and you can select **Region 0** as **Region Selector**.
- The **Width** plus **Offset X** should not be larger than **Width Max**, and **Height** plus **Offset Y** should not be larger than **Height Max**.
- The parameters of ROI may differ by device model.

Go to **Image Format Control** → **Region Selector**, and enter **Width**, **Height**, **Offset X**, and **Offset Y**.

- **Width**: It stands for horizontal resolution in ROI area.
- **Height**: It stands for vertical resolution in ROI area.
- **Offset X**: It refers to the horizontal coordinate of the upper-left corner of the ROI.
- **Offset Y**: It refers to the vertical coordinate of the upper-left corner of the ROI.

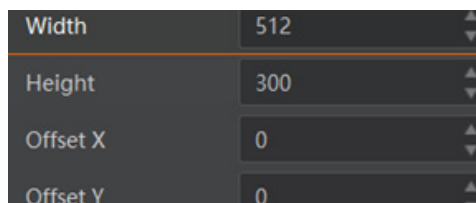

Figure 11-5 Set ROI

11.3 Set Image Reverse

Note

For different models of device, the image reverse function may be different. Please refer to the actual one you got.

Reverse X refers to the image reverses in a horizontal way, and **Reverse Y** refers to the image reverses in a vertical way.

You can click **Image Format Control**, and enable **Reverse X** or **Reverse Y** according to actual demands.



Figure 11-6 Set Image Reverse

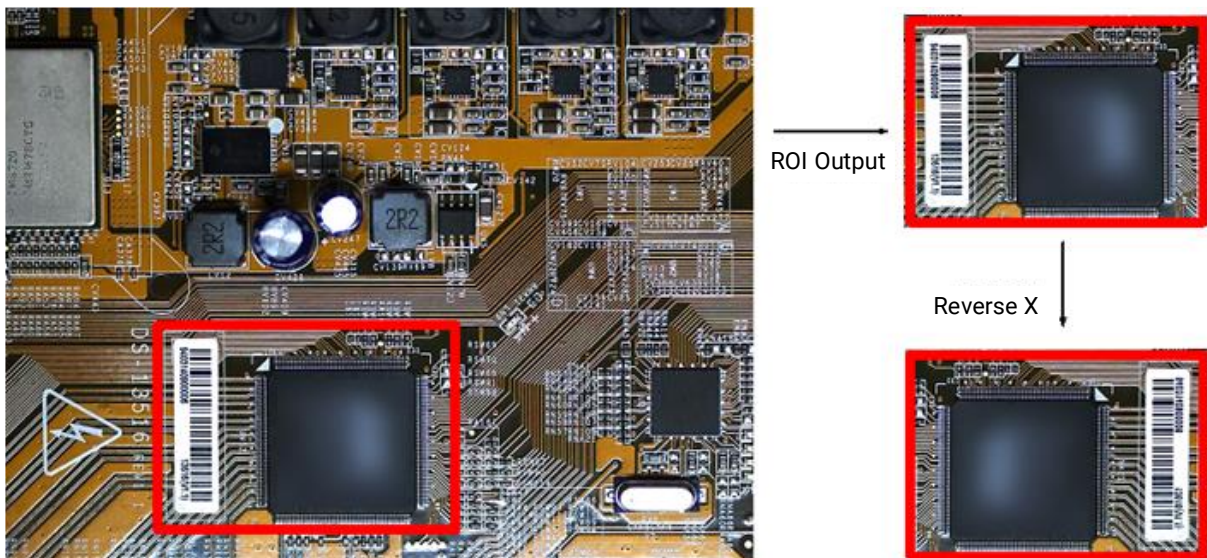

Figure 11-7 Image Reverse Comparison

11.4 Set Pixel Format

This function allows you to set the pixel format of the image data transmitted by the device. Go to **Image Format Control** → **Pixel Format**, and set **Pixel Format** according to actual demands.

Note

- The specific pixel formats may differ by device models.
- With different ADC bit depth, the pixel format and pixel size may differ.

Table 11-1 Pixel Format and Pixel Size

ADC Bit Depth	Pixel Format	Pixel Size (Bits/Pixel)
8	Mono 8, Bayer 8	8
	Mono10 Packed, Mono 12 Packed, Bayer 10 Packed, Bayer 12 Packed	12
	Mono 10/12, Bayer 10/12, YUV422Packed, YUV 422 (YUYV) Packed	16
	RGB 8, BGR 8	24
10	Mono 8, Bayer GB 8	8
	Mono 10 Packed, Mono 12 Packed, Bayer GB 10 Packed, Bayer GB 12 Packed	12
	Mono 10/12, Bayer GB 10/12, YUV422Packed, YUV 422 (YUYV) Packed	16
	RGB 8, BGR 8	24
12	Mono 8, Bayer 8	8
	Mono10 Packed, Mono 12 Packed, Bayer 10 Packed, Bayer 12 Packed	12
	Mono 10/12, Bayer 10/12, YUV422Packed, YUV 422 (YUYV) Packed	16
	RGB 8, BGR 8	24

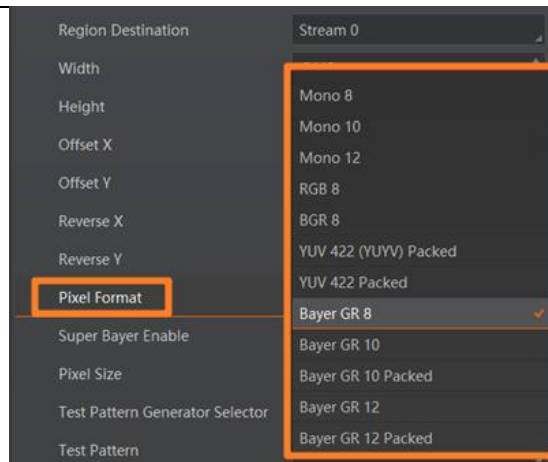

Figure 11-8 Set Pixel Format

With different ADC bit depths and pixel formats, the device's max. frame rate may differ. The larger the device's ADC bit depth value, the better the device's image quality, and the lower the device's frame rate will be.

Note

The ADC bit depth function may differ by device models.

The default output data format of mono device is Mono 8. The default output data format of color device is Bayer 8, and it can be converted into RGB format via pixel interpolation algorithm. The RGB format can be converted into YUV format, and Y component of YUV can be output as Mono 8 format.

Note

If there is no need to identify the color of the object, it is recommended to use a mono camera.

Bayer GR, Bayer GB, Bayer BG, and Bayer RG patterns are shown below.



Figure 11-9 Bayer GR Pixel Pattern



Figure 11-10 Bayer GB Pixel Pattern



Figure 11-11 Bayer BG Pixel Pattern



Figure 11-12 Bayer RG Pixel Pattern

In Bayer pixel format, some color devices support Gamma function, sharpness, contrast ratio, color transformation, super palette control, and LUT function after you enable **Super Bayer Enable**. Go to **Image Format Control** → **Super Bayer Enable**, and enable it according to actual demands.

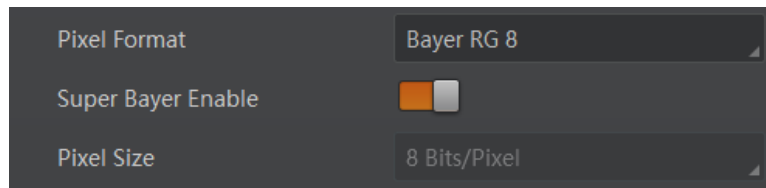

Figure 11-13 Set Super Bayer

Note

- For different models of device, the super Bayer function may be different. Refer to the actual one you got.
 - The super Bayer function is only valid in the Bayer pixel format.
 - After you enable the super Bayer function, the related functions will be shown in the feature tree. If you select other pixel formats, you can set the related parameters under the pixel format.
 - The frame rate is the same in the Bayer pixel format before and after you enable the **Super Bayer Enable**.
-

11.5 Set Image Compression Mode

Note

The function of the image compression is related to device models, firmware and pixel format, and the actual product you purchased should prevail.

Without affecting image quality, this function allows the device to compress data before transmitting to the PC, and output original image data via SDK.

Go to **Image Format Control** → **Image Compression Mode**, and select **HB** as **Image Compression Mode**.

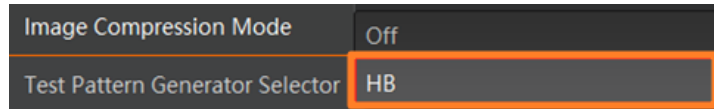

Figure 11-14 Set Image Compression Mode

You can select **Compression** or **Burst** as **High Bandwidth Mode** according to actual demands.

Compression mode only compresses the image data, and does not increase the frame rate with lower power consumption.

Burst mode compresses the image data, and increases the frame rate with higher power consumption.

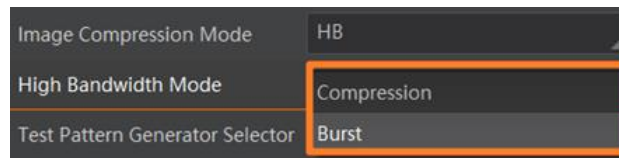

Figure 11-15 Set High Bandwidth Mode

You can view the image compression mode's related parameters like **HB Abnormal Monitor** and **HB Version** in the **Device Control** attribute.

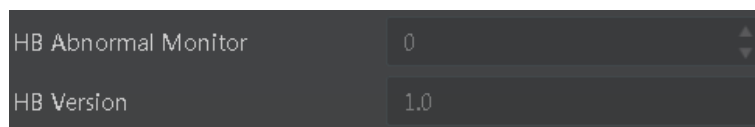

Figure 11-16 HB Abnormal Monitor and Version

- **HB Abnormal Monitor** is used to monitor image stream condition. If the size of compressed image is larger than that of raw image under HB function, this parameter will increase. When this parameter increases rapidly, it is recommended to disable the image compression mode.
- **HB Version** refers to the version of this function.

11.6 Set Test Pattern

Note

The test pattern may differ by device models.

The device supports test pattern function. When there is an exception in real-time image, you can check whether image in test mode have similar problem to determine the reason. This function is disabled by default, and at this point, the output image by the device is real-time image. If this function is enabled, the output image by the device is test image.

Go to **Image Format Control** → **Test Pattern**, and set **Test Pattern** according to actual demands.

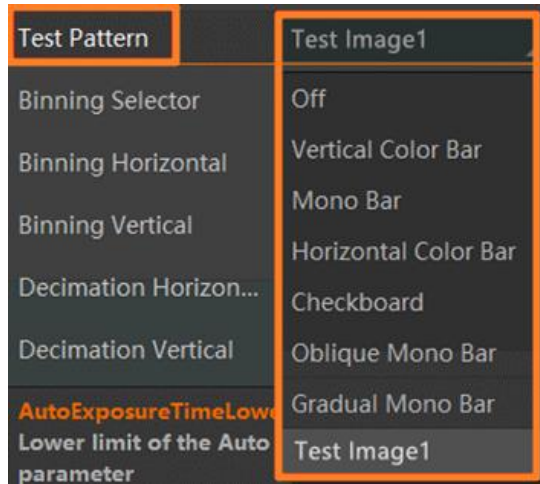

Figure 11-17 Set Test Pattern

The mono device offers 6 test patterns, including **Mono Bar**, **Checkboard**, **Oblique Mono Bar**, **Gradual Mono Bar**, **Test Image 1**, and **Test Isp Mono**.





The color device offers 9 test patterns, including **Mono Bar**, **Checkboard**, **Oblique Mono Bar**, **Gradual Mono Bar**, **Vertical Color Bar**, **Horizontal Color Bar**, **Test Image 1**, **Test Isp Color**, and **Test Isp Mono**.

Note

- The supported patterns may differ by the device model.
- The pattern of the test image 1 may differ by device models.

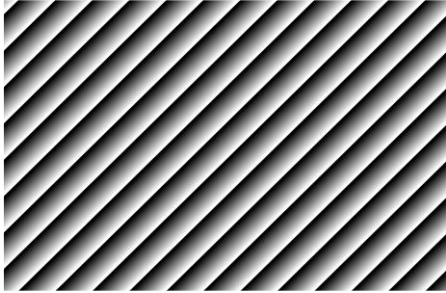
Table 11-2 Test Pattern

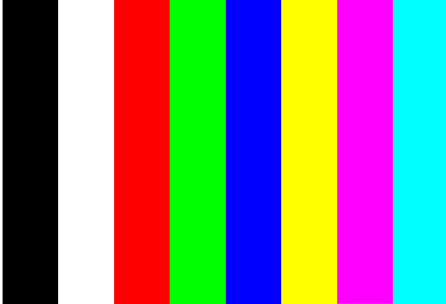
Test Pattern	Image
Mono Bar Test Isp Mono	
Checkboard	

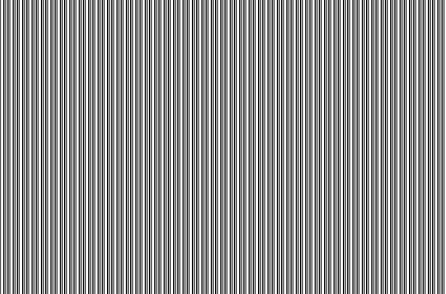
Test Pattern	Image
Oblique Mono Bar	
Gradual Mono Bar	
Vertical Color Bar Test Isp Color	
Horizontal Color Bar	
Test Image 1	

11.7 Set Binning

 **Note**

- **Binning Horizontal** is the image's width, and **Binning Vertical** is the image's height.
- The binning-related functions may differ by device models.

The purpose of setting binning is to enhance sensibility. With binning, multiple sensor pixels are combined as a single pixel to reduce resolution and improve image brightness. For a color device, it merges the pixel values of adjacent pixels of the same color horizontally, as shown below.



Figure 11-18 Binning Horizontal 2



Figure 11-19 Binning Vertical 2

If the horizontal binning coefficient and the vertical binning coefficient of the color device are both configured to 2, the device merges the 4 adjacent sub-pixels of the same color according to the corresponding position, and outputs the merged pixel value as a sub-pixel, as shown below.



Figure 11-20 Binning Horizontal 2 and Binning Vertical 2

Click **Binning Selector**, and set **Binning Horizontal** and **Binning Vertical** according to actual demands.

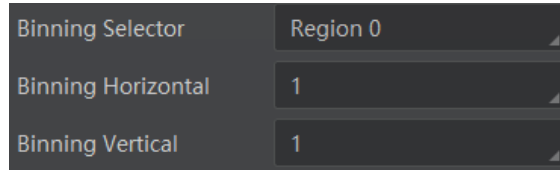

Figure 11-21 Set Binning

The device also supports binning mode function if the binning is 2 × 2 and above. The binning mode defines how pixels are combined if the binning is 2 × 2 and above. Click **Binning Mode**, and select **Sum** or **Average** according to actual demands.

- **Sum**: The values of the affected pixels are summed. This improves the signal-to-noise ratio, but also increases the device's response to light.
- **Average**: The values of the affected pixels are averaged. This greatly improves the signal-to-noise ratio without affecting the device's response to light.

Both binning modes (Sum and Average) reduce the amount of image data to be transferred.

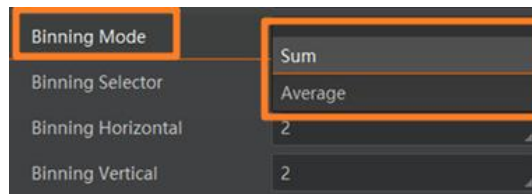

Figure 11-22 Set Binning Mode

11.8 Set Decimation

The decimation feature allows you to reduce the number of sensor pixel columns or rows that are transmitted by the device. This procedure is also known as subsampling. It reduces the amount of data to be transferred and may increase the device's frame rate. Click **Image Format Control**, and set **Decimation Horizontal** and **Decimation Vertical** according to actual demands.

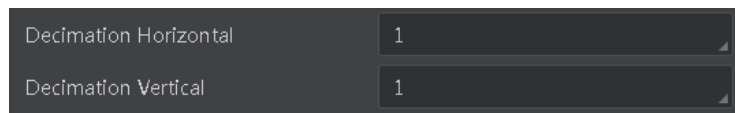

Figure 11-23 Set Decimation

Note

- **Decimation Horizontal** is the image's width, and **Decimation Vertical** is the image's height.
 - The decimation function may differ by device models.
-

11.9 Set Exposure Mode

Note

The exposure mode may differ by device models.

The device supports 2 types of exposure modes, including **Timed** and **Trigger Width**.

- If the **Exposure Mode** is **Timed**, the device's exposure time is controlled by **Exposure Auto** and **Exposure Time**.
- If the **Exposure Mode** is **Trigger Width**, exposure time and level signal duration should be the same, and **Exposure Auto** and **Exposure Time** are invalid.

Note

When the device's **Trigger Mode** is **On**, **Trigger Source** is **Line 0** or **Line 2**, and **Trigger Activation** is **Level High** or **Level Low**, **Trigger Width** can be selected as **Exposure Mode** and the device's exposure time is controlled by the signal duration.

The device offers 2 types of exposure time modes, including **Ultrashort** mode and **Standard** mode.

Note

The range of exposure time may differ by the device model and exposure time mode. Refer to the device's specifications for specific parameters.

11.9.1 Set Ultrashort Mode

In ultrashort mode, the device takes very little exposure time, and the exposure time can only be adjusted manually. Because the exposure time is small, it needs to be used with the light source.

Go to **Acquisition Control** → **Exposure Time Mode**, and set **Exposure Time Mode** according to actual demands.

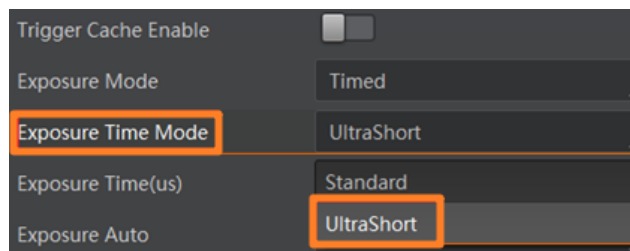

Figure 11-24 Set Ultrashort Mode

Note

- The exposure time mode may differ by device models.
- If the device you got does not support ultrashort exposure time mode, there is no

Exposure Time Mode parameter, and the device supports **Standard** exposure time mode only by default.

11.9.2 Set Standard Mode

In standard mode, the device supports 3 types of exposure mode, including **Off**, **Once** and **Continuous**. Click **Acquisition Control** → **Exposure Auto**, and select **Exposure Auto** according to actual demands.

- **Off**: The device exposures according to the value set in **Exposure Time (μs)**.
- **Once**: The device adjusts the exposure time automatically according to the image brightness. After adjustment, it will switch to **Off** mode.
- **Continuous**: The device adjusts the exposure time continuously according to the image brightness.

When the exposure mode is set as **Once** or **Continuous**, the exposure time should be within the range of **Auto Exposure Time Lower Limit (μs)** and **Auto Exposure Time Upper Limit (μs)**.

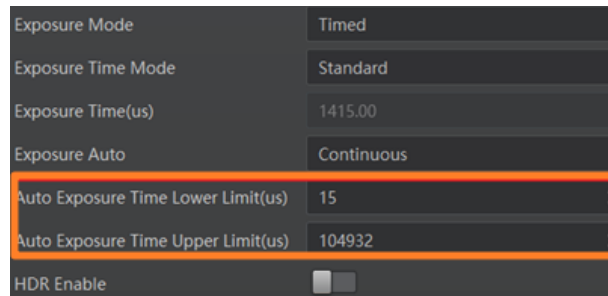

Figure 11-25 Set Exposure Time Under Once or Continuous Mode

11.10 Set Brightness

The device brightness refers to the brightness when the device adjusts image under **Once** or **Continuous** exposure mode.

Note

- You should enable **Once** or **Continuous** exposure mode or gain mode first before setting brightness. Refer to section [Set Exposure Mode](#) and section [Set Analog Gain](#) for details.
 - After setting brightness, the device will automatically adjust exposure time or analog gain to let image brightness reach target one. Under **Once** or **Continuous** exposure mode, the higher the brightness value, the brighter the image will be under auto exposure mode or auto gain mode.
 - The range of brightness is between 0 and 255.
-

Table 11-3 Brightness Example

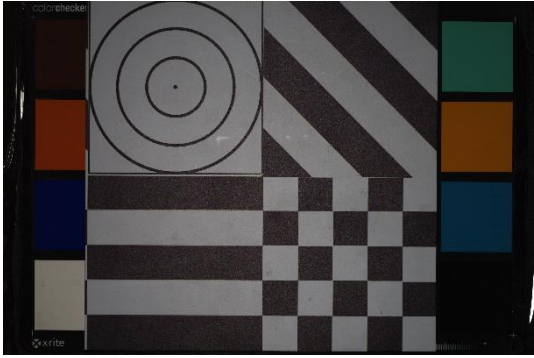
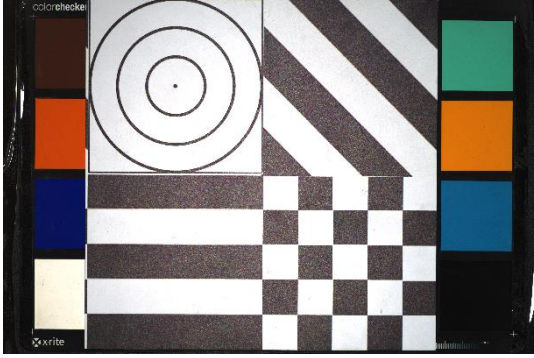
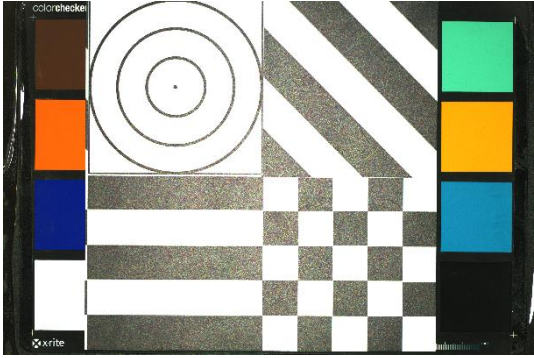
Brightness Value	Image
Brightness=25	
Brightness=75	
Brightness=120	

Go to **Analog Control** → **Brightness**, and enter **Brightness** according to actual demand.

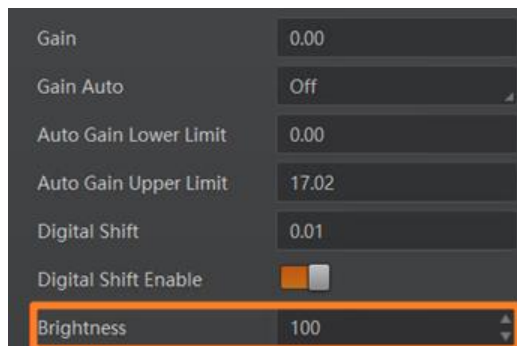

Figure 11-26 Set Brightness

11.11 Set Sharpness

Note

- The sharpness function is valid in Mono and YUV pixel formats, and is disabled by default.
 - The range of sharpness may differ by the device model.
-

The device supports sharpness function that can adjust the sharpness level of the image edge. You can set sharpness as shown below.

Go to **Analog Control** → **Sharpness Enable**, enable **Sharpness Enable**, and enter **Sharpness** according to actual demands.

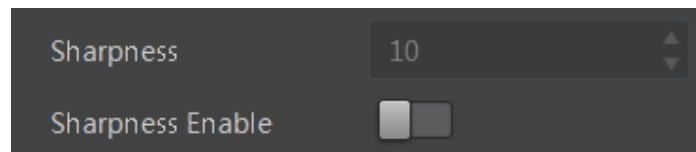

Figure 11-27 Set Sharpness

11.12 Set Contrast Ratio

Note

- The contrast ratio function may differ by device models.
 - Make sure that the live view is enabled, and Gamma correction and LUT function is disabled before using the contrast ratio function.
 - Regarding the color device in Bayer pixel format, you need to enable **Super Bayer Enable** first before using contrast ratio function.
 - The range of **Contrast Ratio** is from 0 to 100.
-

The device supports the contrast ratio function that adjusts the intensity of light and darkness and color. The larger the contrast ratio, and more clear the image is.

Go to **Analog Control**, enable **Contrast Ratio Enable**, and set **Contrast Ratio** according to actual demands.

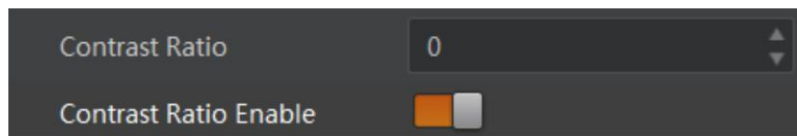

Figure 11-28 Set Contrast Ratio

11.13 Set White Balance

Note

White balance is only available for color devices. In Mono pixel format, this function is not supported.

The white balance refers to the device color adjustment depending on different light sources. Adjust the R/G/B ratio to ensure that the white regions are white under different color temperatures. Ideally, the proportion of R/G/B in the white region is 1:1:1.

The device supports 3 types of white balance mode, including **Off**, **Once** and **Continuous**. Click **Analog Control** → **Balance White Auto**, and select **Balance White Auto** according to actual demands.

- **Off**: You need to set the R, G, B ratio manually via **Balance Ratio Selector** and **Balance Ratio**. The range is from 1 to 4095, and 1024 means ratio is 1.0.
- **Once**: Adjust the white balance for a certain amount of time then stop.
- **Continuous**: Adjust the white balance continuously.

It is recommended to correct white balance when there is great difference between the device's color effect and actual effect. You can correct white balance as shown below.

Auto Correction

Steps

1. Put a white paper in the range of the device's field of view, and make sure the paper covers the entire field of view.
2. Set exposure and gain.

Note

It is recommended to set image pixel value between 120 and 160.

3. Select **Wide** as **AWB Color Temperature Mode** to let the device adjust white balance again if the image's color effect is not good under the default condition of **Balance White Auto** is **Continuous** and **AWB Color Temperature Mode** is **Narrow**.

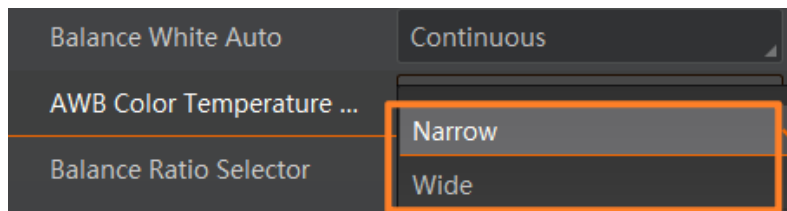

Figure 11-29 Set Parameters

Manual Correction

If there is still great difference between correction effect and actual color, it is recommended to manually correct white balance according to following steps.

Steps

Note

- For specific **Balance Ratio Selector** value, please refer to the actual condition.
 - In order to avoid repeated correction after restarting the device, it is recommended to save white balance parameter to **User Set** after white balance correction. You can refer to the section [Save User Set](#) and [Load User Set](#) for details.
 - If the light source and color temperature change, you need to correct white balance again.
 - If the pixel format is Bayer, you can correct white balance via the white balance tool in the client software with 3.2.0 version and later. Refer to **Machine Vision Software User Manual** for details.
-

1. Select **Off** as **Balance White Auto**. At this time, **Balance Ratio** is 1024.
2. Find corresponding R/G/B channel in **Balance Ratio Selector**.
3. Find device's R/G/B value.
4. Take **Green** as correction standard, and manually adjust other two channels (R channel and B channel) to let these three channels have same value.

11.14 Set Sequencer Control and HDR

The device supports sequencer or HDR functions, which allow you to configure multiple groups of parameters to acquire images.

Note

- The device cannot support sequencer and HDR functions at the same time.
 - The sequencer or HDR function may differ by device models.
-

11.14.1 Set Sequencer

If the device supports sequencer, you can configure multiple groups of parameters including exposure time and gain. The principle of the sequencer is shown below.

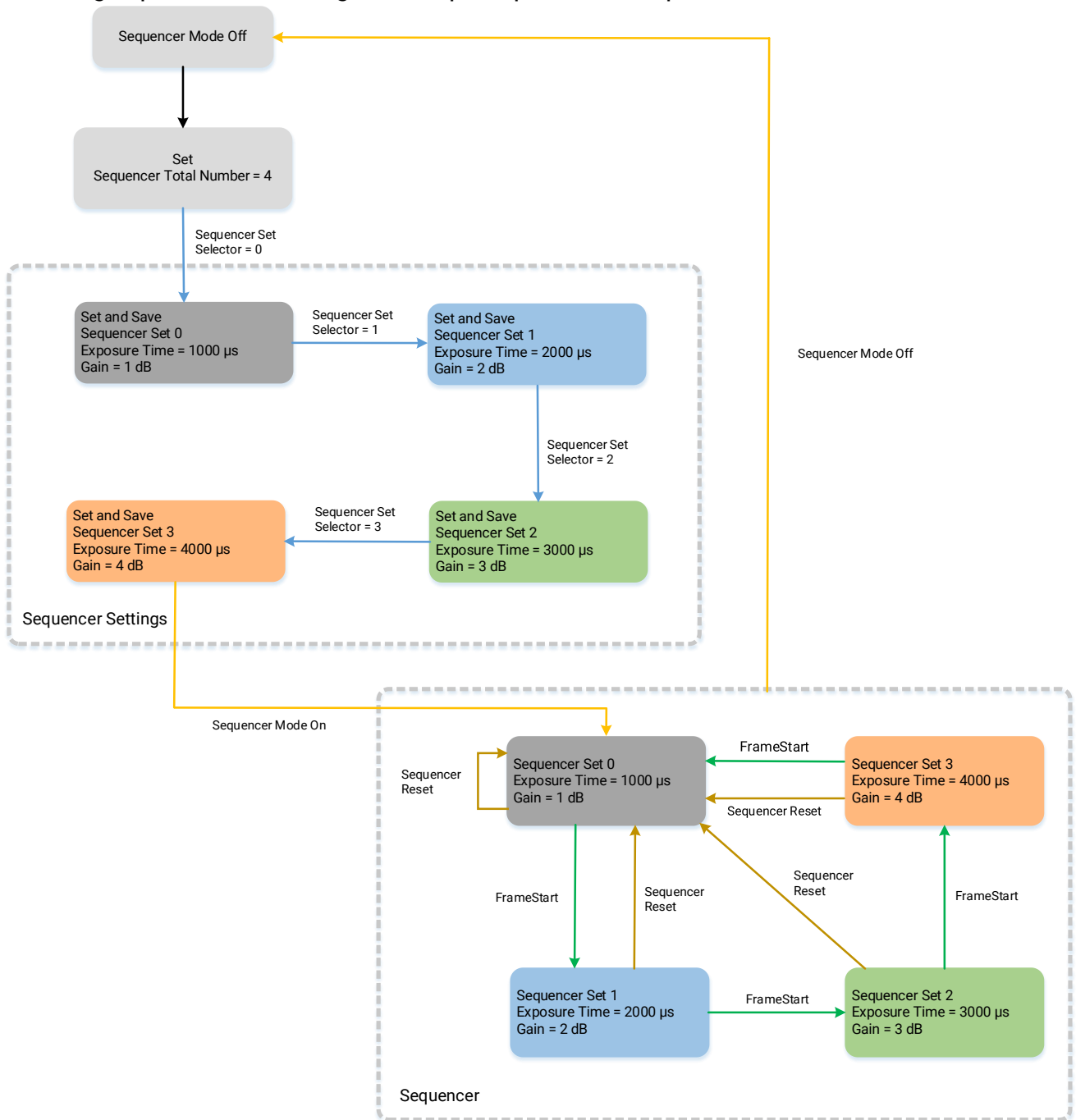

Figure 11-30 Principle of Sequencer

Note

You cannot configure parameters like trigger width, exposure time mode during sequencer.

Steps

1. Go to **Sequencer Control**, select **Off** as **Sequencer Mode**, and **On** as **Sequencer Configuration Mode**.

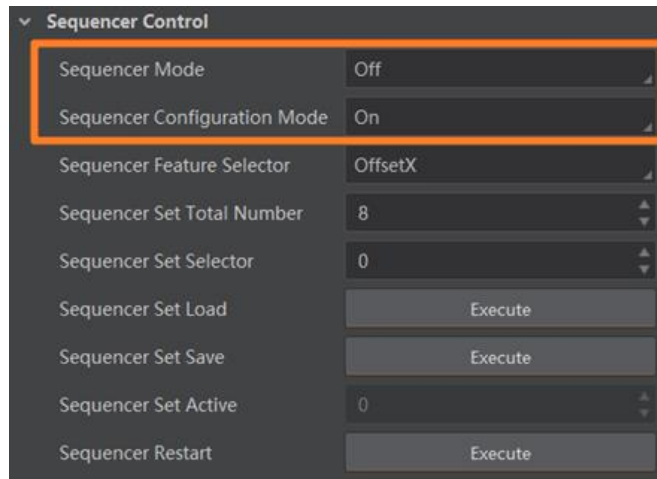

Figure 11-31 Set Sequencer Control

2. Set **Sequencer Set Total Number** to configure the number of groups to join sequencer according to actual demands.
3. Set **Sequencer Set Selector** to select one group of parameters, and set **Sequencer Feature Selector** to configure specific parameters.

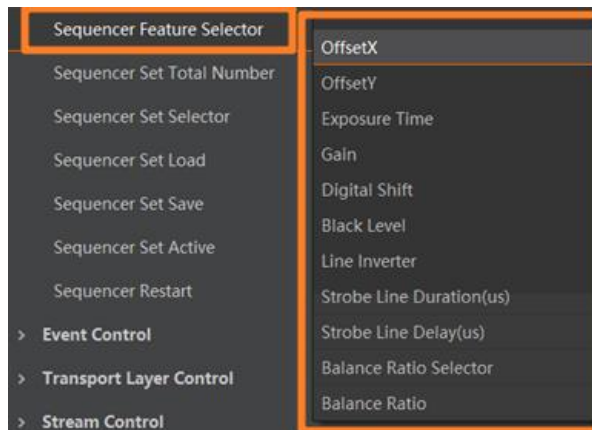

Figure 11-32 Sequencer Feature Selector

Note

- You should go to the corresponding parameters to set their detailed parameters.
- The sequencer function does not support ultrashort exposure mode.

4. (Optional) Click **Execute** in **Sequencer Set Load** to load selected parameters in **Sequencer Set Selector**.
 5. Click **Execute** in **Sequencer Set Save** to save the selected group of parameters.
 6. Repeat step 3 to step 5 to configure other group of parameters.
 7. Select **On** as **Sequencer Mode** to start sequencer after configuration.
-

 **Note**

You cannot configure detailed parameters of group of parameters once sequencer is started.

8. (Optional) Click **Execute** in **Sequencer Restart** to let the sequencer start from the beginning group.
-

 **Note**

The **Sequencer Restart** is valid when image acquisition is stopped.

9. (Optional) After sequencer is started, you can view which group is in sequencer via the **Sequencer Set Active**.

11.14.2 Set HDR

 **Note**

- The HDR function may differ by device models.
 - The device supports HDR (High Dynamic Range) function that the device acquires images based on customized settings, and each with its own exposure time and gain.
 - The images are not combined to form an HDR image in the HDR mode.
-

Steps

1. Go to **Acquisition Control** → **HDR Enable**, and enable **HDR Enable**.
 2. Set **HDR Selector** and corresponding **HDR Shutter** and **HDR Gain**.
-

 **Note**

- Up to 4 groups of parameters can be configured.
 - HDR gain function may differ by device model.
-

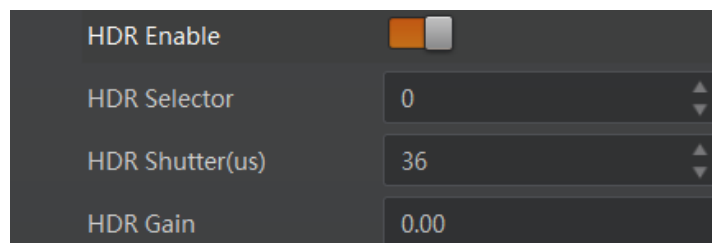

Figure 11-33Set HDR

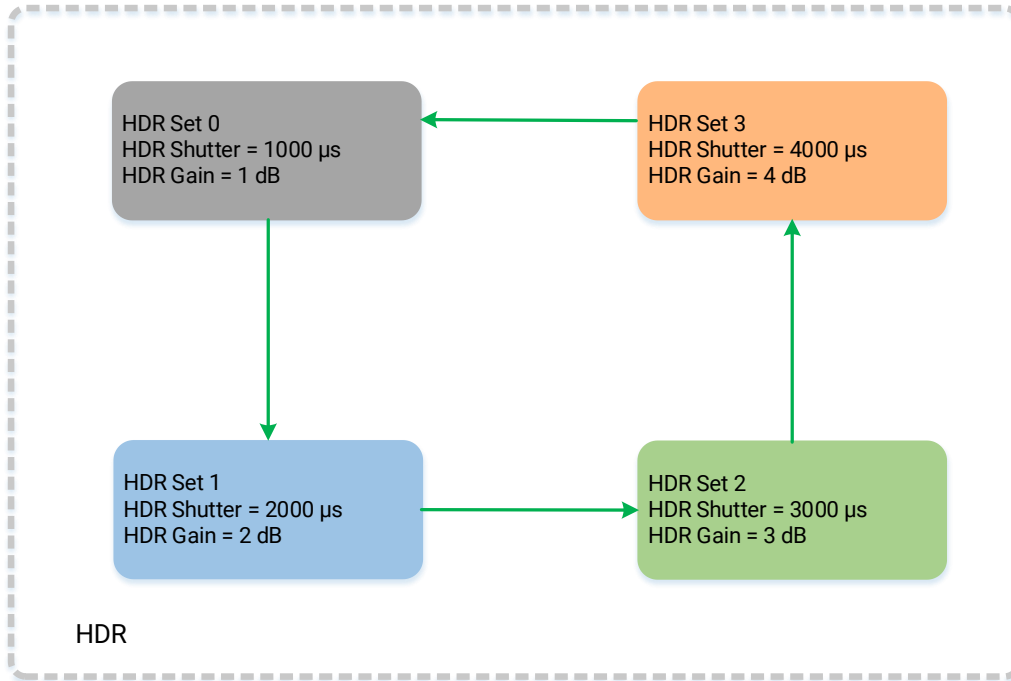

Figure 11-34 HDR Demonstration (Four Groups)

11.15 Set Gain

Note

The gain function may differ by device models.

The device has 2 types of gain, including the analog gain and digital gain. The analog gain is applied before the signal from the device sensor is converted into digital values, while digital gain is applied after the conversion.

11.15.1 Set Analog Gain

Note

- The analog gain parameter name may differ by device of different models or firmware. The analog gain parameter name can be **Preamp Gain** or **Gain** which have different settings method.
- When the analog gain parameter is **Preamp Gain**, you can set it manually only.

Preamp Gain

Go to **Analog Control** → **Preamp Gain**, and set **Preamp Gain** according to actual demands.

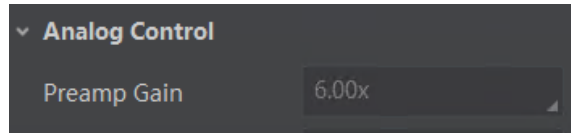

Figure 11-35 Preamp Gain

Gain

The device supports 3 types of gain mode, including **Off**, **Once** and **Continuous**. Click **Analog Control** → **Gain Auto**, and select **Gain Auto** according to actual demands.

- **Off**: The device adjusts gain according to the value configured by user in **Gain**.
- **Once**: The device adjusts the gain automatically according to the image brightness. After adjusting, it will switch to **Off** mode.
- **Continuous**: The device adjusts the gain continuously according to the image brightness.

When the gain mode is set as **Once** or **Continuous**, the gain should be within the range of **Auto Gain Lower Limit (dB)** and **Auto Gain Upper Limit (dB)**.

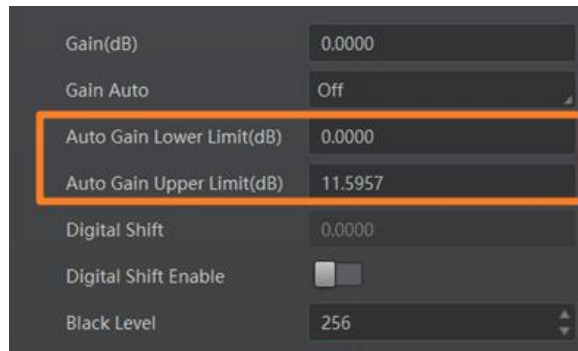

Figure 11-36 Set Gain under Once or Continuous Mode

Note

When increasing gain, the image noise will increase too, which will influence image quality. If you want to increase image brightness, it is recommended to increase the device's exposure time first. If the exposure time reaches its upper limit, and at this point, you can increase gain.

11.15.2 Set Digital Gain

Apart from analog gain, the device supports digital gain function. When analog gain reaching its upper limit and the image is still too dark, it is recommended to improve

image brightness via digital gain.

Click **Analog Control**, enable **Digital Shift Enable**, and enter **Digital Shift** according to actual demands.

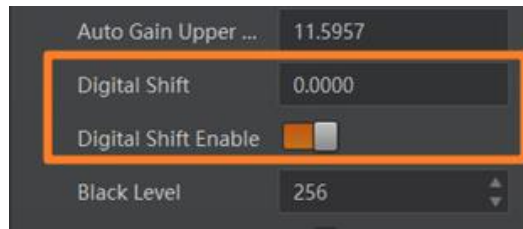

Figure 11-37 Set Digital Gain

Note

When increasing the digital gain, the image noise will greatly increase too, which will severely influence image quality. It is recommended to use analog gain first, and then to adjust digital gain if the analog gain cannot meet demands.

11.16 User Set Customization

This function allows you to save or load device settings. The device supports four sets of parameters, including one default set and three user sets, and the relation among four sets of parameters is shown below.

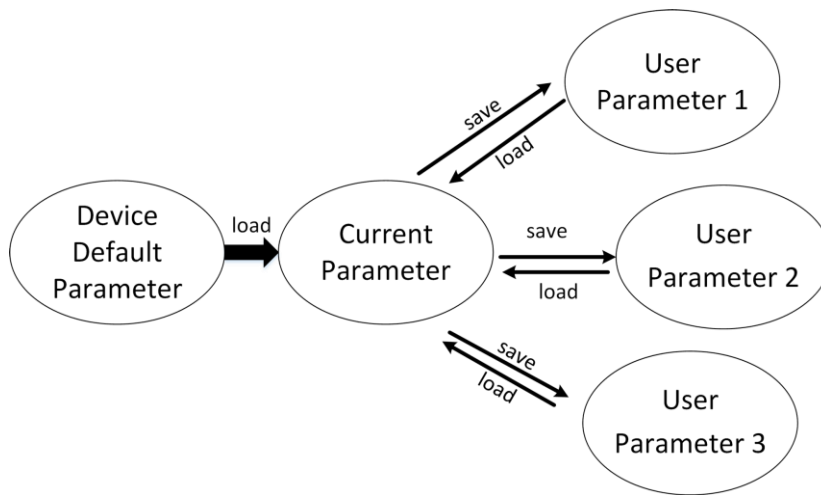

Figure 11-38 Parameter Relation

Note

After setting user parameters, it is recommended to save user parameters and select them as the default parameters.

11.16.1 Save User Set

Steps

1. Go to **User Set Control**, and select a user set in **User Set Selector**.
-

Note

Here we take selecting **User Set 1** as an example.

2. Click **Execute** in **User Set Save** to save parameter.
3. View **User Set Save Status**:
 - Saving: User parameters are being saved.
 - Ready: User parameters have been saved.

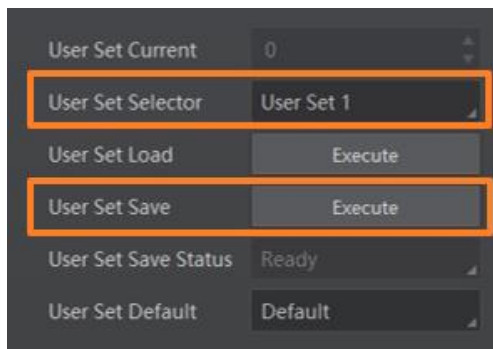

Figure 11-39 Save User Set

Note

The parameter of **User Set Save Status** may differ by device models.

11.16.2 Load User Set

Note

Loading user set is available only when the device is connected but without live view.

Steps

1. Go to **User Set Control**, and select a user set in **User Set Selector**.
-

Note

Here we take selecting **User Set 1** as an example.

2. Click **Execute** in **User Set Load** to load parameter.

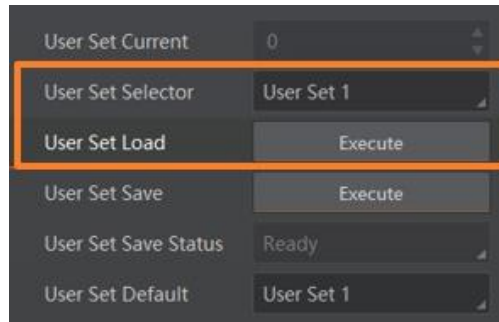

Figure 11-40 Load User Set

11.16.3 Set User Default

You can also set default parameter by going to **User Set Control** and selecting a user set in **User Set Default**.

Note

- The User Set Default is the user set that will be loaded upon power cycling the camera
 - Here we take selecting **User Set 1** as an example.
-

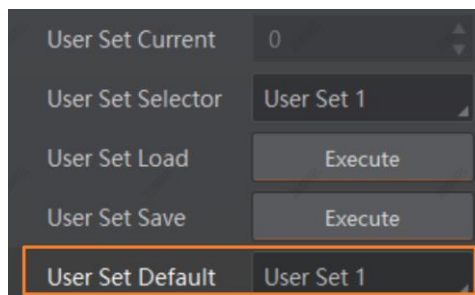

Figure 11-41 Set User Default

Chapter 12 Advanced Functions

12.1 Set Black Level

Note

The default value of black level may differ by device models.

The black level function can adjust the gray value offset of the output data, determining the average gray value when the sensor is not exposed to light.

Go to **Analog Control** → **Black Level Enable**, enable **Black Level Enable**, and enter **Black Level** according to actual demands.

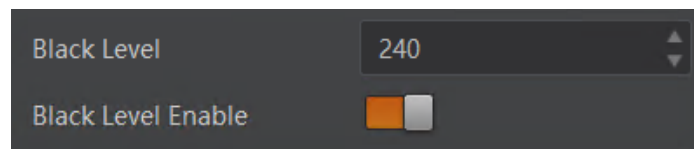

Figure 12-1 Set Black Level

12.2 Set Gamma Correction

Note

The Gamma correction function may differ by device models or pixel formats.

The device supports Gamma correction function. Generally, the output of the device's sensor is linear with the photons that are illuminated on the photosensitive surface of the sensor. Gamma correction provides a non-linear mapping mechanism as shown below.

- Gamma between 0.5 and 1: image brightness increases, dark area becomes brighter.
- Gamma between 1 and 4: image brightness decreases, dark area becomes darker.

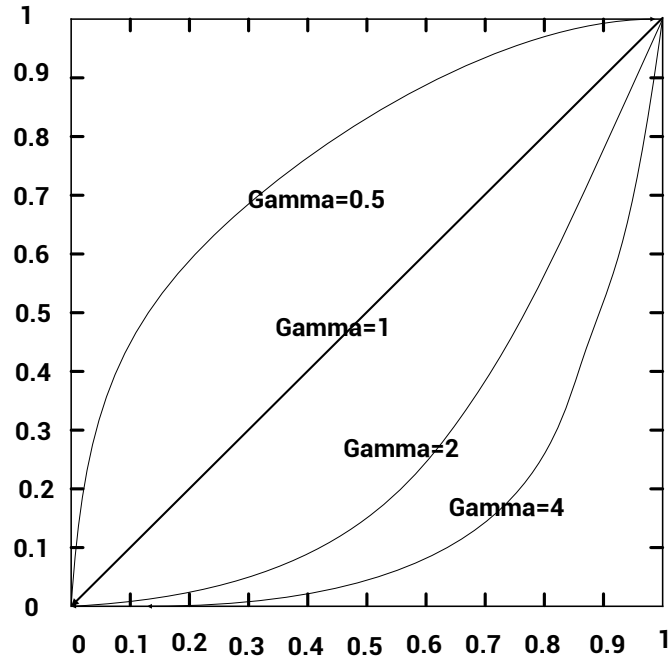

Figure 12-2 Set Gamma Correction

Table 12-1 Gamma Correction Example

Gamma Value	Image
Gamma=0.5	
Gamma=1.5	

Gamma Value	Image
Gamma=2	

There are 2 types of Gamma correction, including **User** mode and **sRGB** mode. Settings method is different as shown below.

User Mode

Steps

1. Go to **Analog Control** → **Gamma Selector**.
2. Select **User** as **Gamma Selector**.
3. Enable **Gamma Enable** to enable it.
4. Enter **Gamma** according to actual demands, and its range is from 0 to 4.

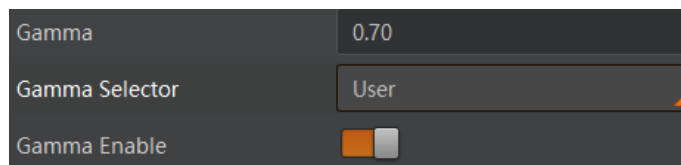

Figure 12-3 Set User Mode

sRGB Mode

Steps

1. Go to **Analog Control** → **Gamma Selector**.
2. Select **sRGB** as **Gamma Selector**.
3. Enable **Gamma Enable** to enable it.

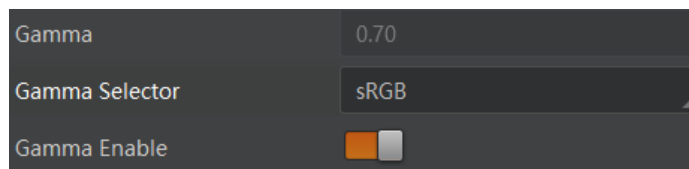

Figure 12-4 Set sRGB Mode

12.3 Set Digital Noise Reduction

Note

- The digital noise reduction function may differ by device models.
 - Excessive noise reduction will affect the image details.
-

The function of digital noise reduction can increase the image's SNR and improve its quality.

Steps

1. Go to **Analog Control** → **Digital Noise Reduction Mode**.
2. Select **Expert** as **Digital Noise Reduction Mode**.
3. Enter **Denoise Strength** and **Noise Correct** according to actual demands.
 - **Denoise Strength** refers to the intensity of the digital noise reduction, you can increase it to have a better effect.
 - **Noise Correct** refers to the noise horizontal correction value, and it is used to adjust the noise curve.

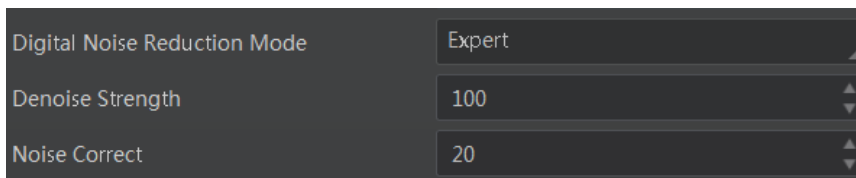

Figure 12-5 Set Digital Noise Reduction

12.4 Set AOI

Note

- The AOI function may differ by device models.
 - AOI 1 is used to adjust the brightness when the device is in once or continuous exposure mode, and AOI 2 is used to adjust the white balance when the color device is in once or continuous white balance mode.
-

The device supports AOI function that can adjust the brightness and white balance of the entire image based on the area you selected.

Steps

1. Click **Analog Control** → **Auto Function AOI Selector**, and select **AOI 1** or **AOI 2**.
2. Enter **Auto Function AOI Width**, **Auto Function AOI Height**, **Auto Function AOI Offset X**, and **Auto Function AOI Offset Y** according to actual demands.
3. Enable **Auto Function AOI Usage Intensity** if **AOI 1** is selected as **Auto Function AOI Selector**. Or enable **Auto Function AOI Usage White Balance** if **AOI 2** is selected as **Auto Function AOI Selector**.

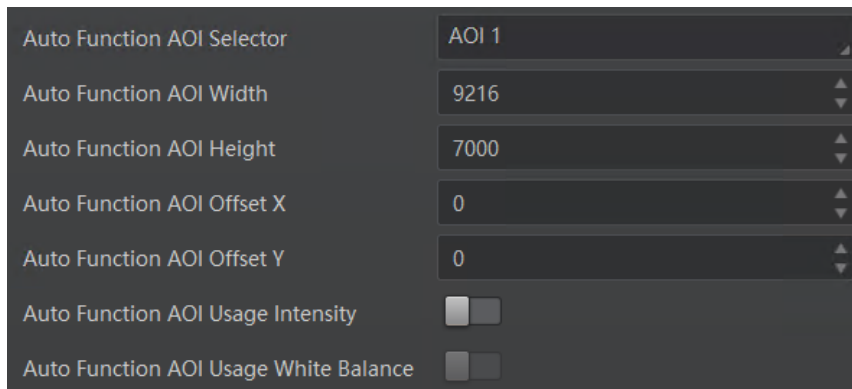

Figure 12-6 Set AOI

12.5 Set Color Transformation Control

Note

- The function of color transformation control is only available for color devices, and may differ by device model.
- Currently, **RGB to RGB** is available for **Color Transformation Selector** only.

After the image is processed by the white balance, the overall image will be dark, and at the same time, various colors may deviate from their standard values to varying degrees. At this time, it is necessary to multiply the color of the image by the correction matrix to correct each color to its standard value, so that the overall color of the image is more vivid. The color correction function is implemented by multiplying each RGB component by a correction matrix. The currently supported color conversion module is RGB to RGB.

Two methods are available to set color transformation control.

- Method 1:

Steps

1. Go to **Color Transformation Control**, and enable **CCM Enable**.
2. Select **Color Transformation Value Selector**, and set **Color Transformation Value** according to actual demand.

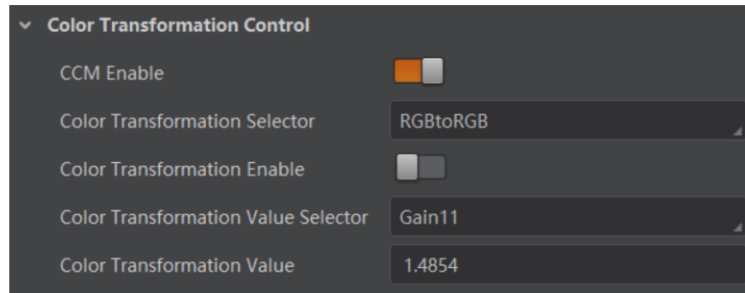

Figure 12-7 Method 1

Note

- **CCM Enable** is used to enable color correction function. If the device you purchased does not have **CCM Enable**, then the color correction function is enabled by default.
- Color correction is achieved by adjusting the values of the parameters in **Color Transformation Value Selector**, where Gain00, Gain10, and Gain20 adjust the R component of the red pixel, Gain01, Gain11, and Gain21 adjust the G component of the green pixel, and Gain02, Gain12, and Gain22 adjust the B component of the blue pixel.
- Method 2: Go to **Color Transformation Control**, enable **Color Transformation Enable**, set **Hue** and **Saturation** to adjust **Color Transformation Value**.

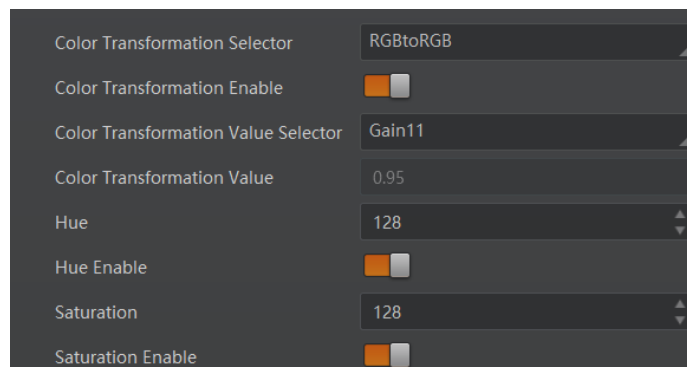

Figure 12-8 Method 2

12.6 Set Hue

Note

- The hue function is only available for color devices.
- In Mono pixel format, hue function is not supported.
- The range of hue is between 0 and 255.

Adjusting the hue shifts the colors of the image. After hue is set, the device will perform color correction based on the hue value to bring the image tone to the target value. For example, when hue is set to 128, the red in the image appears as real red. When hue is 0,

the hue is reversed 128 degrees counterclockwise, and red becomes blue. When hue is 255, the hue rotates 128 degrees clockwise, and red becomes green. Image examples of different hue values are shown below.

Table 12-2 Hue Example

Hue Value	Image
Hue=0	
Hue=128	
Hue=255	

Before You Start

Make sure the **Pixel Format** of the color device is **Bayer, YUV, RGB, or BGR**.

Steps

1. Go to **Color Transformation Control**, and enable **Hue Enable**.
2. Enter **Hue** according to actual demands.



Figure 12-9 Set Hue

Note

- For some devices, you should go to **Analog Control** and enable **Hue Enable** to set the hue function.
- It is not recommended to edit the default values. If you have any questions, please contact technical support.



12.7 Set Saturation

Note

- The saturation function is only available for color devices.
- In Mono pixel format, saturation function is not supported.
- The range of saturation is between 0 and 255.

Adjusting the saturation changes the colorfulness of the colors. A higher saturation, for example, makes colors easier to distinguish. Image examples of different saturation values are shown below.

Table 12-3 Saturation Example

Saturation Value	Image
Saturation=0	
Saturation =128	

Saturation Value	Image
Saturation =255	

Before You Start

Make sure the **Pixel Format** of the color device is **Bayer, YUV, RGB, or BGR**.

Steps

1. Go to **Color Transformation Control**, and enable **Saturation Enable**.
2. Enter **Saturation** according to actual demands.

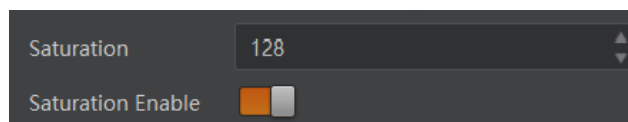

Figure 12-10 Set Saturation

Note

For some devices, you should go to **Analog Control** and enable **Saturation Enable** to set the saturation function.

12.8 Set Super Palette Control

Note

- The function of super palette control may differ by device models.
- Regarding the color device in Bayer pixel format, you need to enable **Super Bayer Enable** first before using super palette control function.
- Make sure the **Pixel Format** of the color device is **Bayer, YUV, RGB, or BGR**.

The super palette control function allows you to select different color areas in the image to set customized hue and saturation values.

Steps

1. Go to **Super Palette Control**, and enable **Super Palette Enable**.
2. Select **Super Palette Selector**.

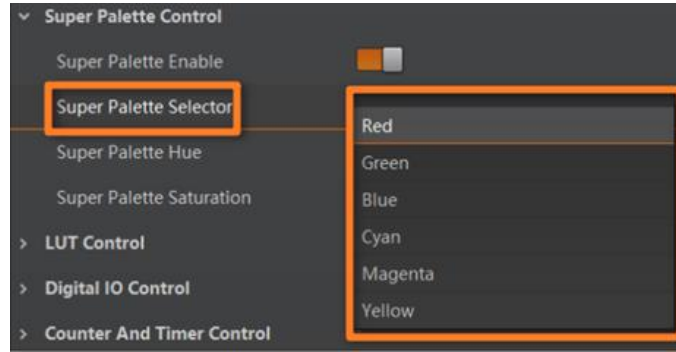

Figure 12-11 Super Palette Selector

3. Set corresponding **Super Palette Hue** and **Super Palette Saturation** according to actual demands.

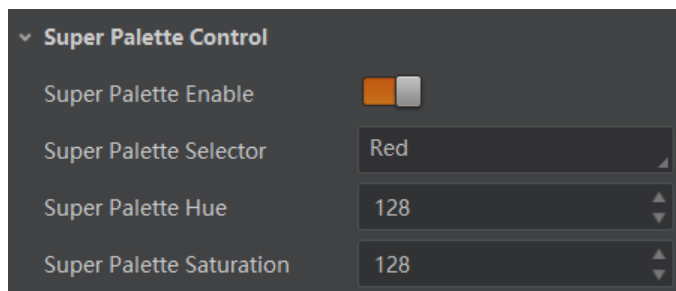

Figure 12-12 Set Super Palette Control

12.9 Set Sensor Mode

Note

The sensor mode function may differ by device models.

The device provides two types of sensor mode, including high full well capacity and high sensitivity.

- **High Full Well Capacity:** It greatly improves the overall brightness of images and is applicable to low-light environment.
- **High Sensitivity:** It improves the image's sensitivity.



Figure 12-13 Set Sensor Mode

12.10 Set WDR Mode

 **Note**

The WDR function may differ by device models.

The WDR function makes the device have a stable imaging ability in a changing environment between brightness and darkness.

Steps

1. Go to **Acquisition Control** → **WDR Mode**.
2. Select **On** as **WDR Mode** to enable the function or **Off** to disable it.
3. Set **WDR Level** according to actual demands if the **WDR Mode** is **On**. You can select three levels: **High** > **Standard** > **Low**.

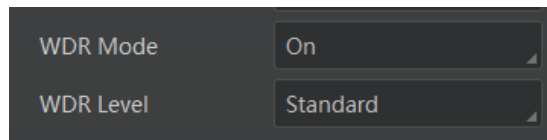





Figure 12-14 Set WDR Mode

Image examples of different settings are shown below.

Table 12-4 WDR Example

WDR Mode	WDR Level	Image
Off	/	
On	Standard	

WDR Mode	WDR Level	Image
	Low	
	High	

12.11 Set Shading Correction

Note

The specific shading correction types that devices support and configuration methods may differ by device models.

The device supports shading correction function that improves the image uniformity when you acquire a non-uniformity image due to external conditions. The supported shading correction type includes LSC correction, FPNC correction, and PRNUC correction.

12.11.1 LSC Correction

LSC correction stands for Lens Shading Correction that eliminates non-uniform illumination brought by lens. The images before LSC correction and after correction are shown below.

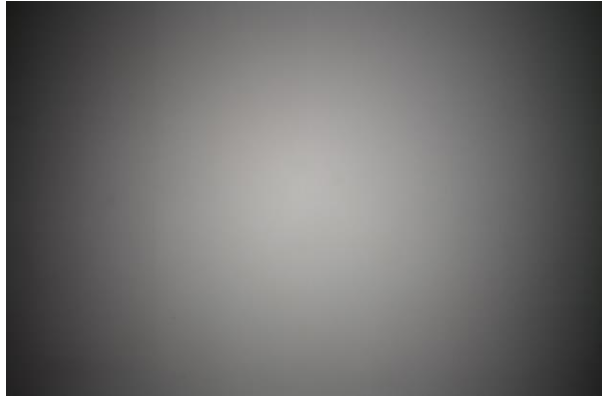

Figure 12-15 Before LSC Correction

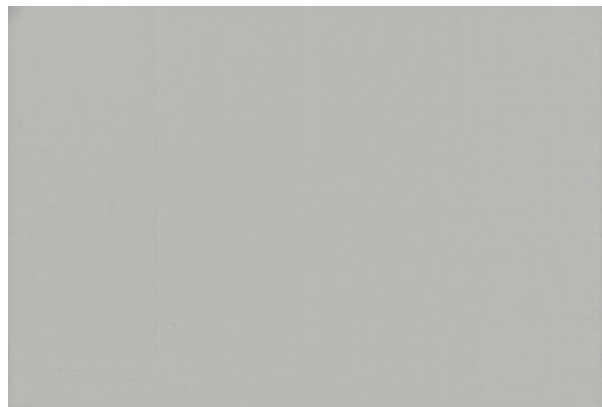

Figure 12-16 After LSC Correction

Steps

1. Go to **Shading Correction**, and select **LSC Correction** as **Shading Selector**.
2. Click **Execute** in **Activate Shading** to let the client software automatically calculate the data, or you can manually select **brightest** or **setting value** in **LSC Calib Select** to calculate the data.
 - **brightest**: Use the brightest area in the image as a reference to calculate brightness differences of other areas, and then correct the other parts of the image based on the calculated brightness differences.
 - **setting value**: You can customize the reference brightness. When the brightness of a certain area in the image is lower than the reference brightness, it will be corrected. After selecting **setting value**, you can set the effective brightness via **LSC Target Gray**.

Note

The supported methods for calculating correction data may differ by the device model.

3. Enable **LSC Enable**.

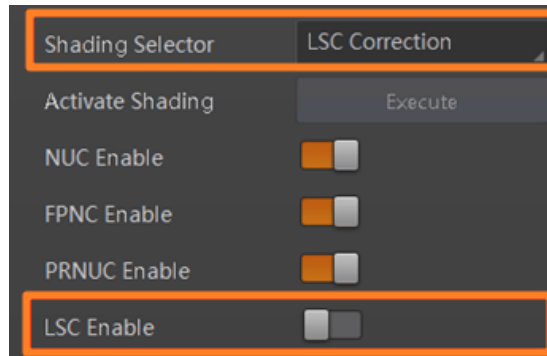

Figure 12-17 LSC Correction

Note

- LSC correction should be executed in full resolution. If you are only interested in a certain region of the image, you can set a Region of Interest (ROI) after correction.
 - Specific steps for executing LSC correction may differ by device models.
 - For some device models, you should execute correction again after setting Binning.
-

12.11.2 Other Corrections

Other corrections include FPNC correction and PRNUC correction. The images before correction and after correction are shown below.

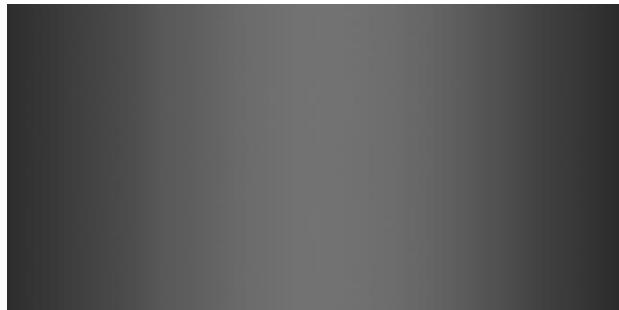

Figure 12-18 Before Correction



Figure 12-19 After Correction

Go to **Shading Correction**, and enable **NUC Enable**. The **FPNC Enable** and **PRNUC Enable** will be automatically enabled or disabled according to the device's condition.

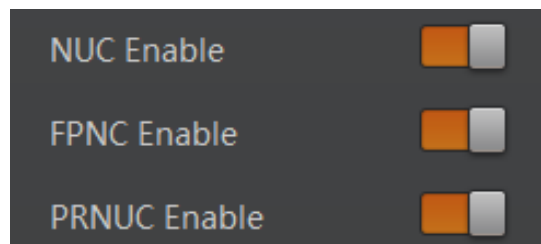

Figure 12-20 Other Corrections

12.12 Set LUT

A Look-Up Table (LUT) is a customizable grayscale-mapping table. You can stretch and amplify the grayscale range. The mapping can be linear or customized curve.

Note

- You cannot use Gamma correction function and LUT function at the same time.
 - The range of the LUT index is from 0 to 1023.
 - The value of LUT value is four times the value of LUT index by default. With different ADC bit depth, the range of the LUT value may differ.
 - The parameter of **LUT Save** may differ by device models. If the device has no **LUT Save**, the settings you configured will be saved in the device in real time.
 - For different LUTs, after you set **LUT Index** and **LUT Value**, you should click **Execute** in **LUT Save** respectively.
-

Steps

1. Click **LUT Control**, and enable **LUT Enable**.
2. Select one group in the **LUT Selector**.
2. Enter **LUT Index** and **LUT Value** according to actual demands.
3. Click **Execute** in **LUT Save** to save it.

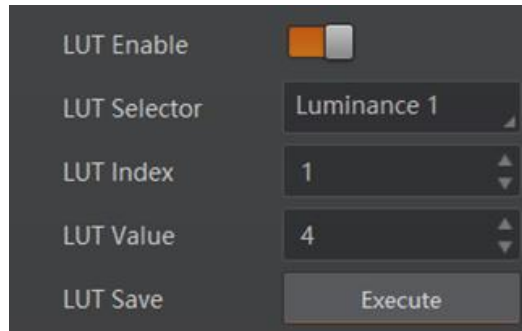

Figure 12-21 Set LUT

Chapter 13 Other Functions

13.1 Device Control

 **Note**

The specific device control parameters may differ by device models.

In **Device Control**, you can view device information, edit device name, reset device, etc. The specific parameters in **Device Control** are shown below.

Table 13-1 Parameters of Device Control

Parameter	Read/Write	Description
Device Scan Type	Read Only	It is the scan type of the device's sensor.
Device Vendor Name	Read Only	It is the name of the manufacturer of the device.
Device Model Name	Read Only	It is the model of the device.
Device Manufacturer Info	Read Only	It is the manufacturer information about the device.
Device Version	Read Only	It is the device version.
Device Firmware Version	Read Only	It is the device firmware version and FPGA version.
Device Serial Number	Read Only	It is device's serial number.
Device User ID	Read & Write	Device name and it is empty by default. You can set according to your preference. <ul style="list-style-type: none"> • If User ID is empty, the client software displays the device model. • If you set it, the client software displays the User ID you set.
Maximum Device Response Time	Read Only	It is the device max. response time. If it has no response after this time, the device is disconnected.
Device Manifest Table Address	Read Only	It is the ID of GenICam XML that the device selects.
Device SBRM Address	Read Only	It is the base address register.
Device Timestamp	Read Only	It is the device timestamp.

USB3.0 Area Scan Camera User Manual

Parameter	Read/Write	Description
Device Timestamp Latch	Read & Write	Click Execute to get the device timestamp.
Device Timestamp Increment	Read Only	It is the max. value of the device timestamp.
Device Protocol Endianness	Read Only	It is the device protocol endianness.
Device Implementation Endianness	Read Only	It is the device operating endianness.
Device Uptime (s)	Read Only	It is the period of time when device is powered up.
Board Device Type	Read Only	It is the device type.
USB Interface Selector	Read & Write	You can select the main or sub USB interface for data transmission.
USB Speed Mode	Read Only	It is the speed mode of USB interface, including High Speed (USB2.0) and Super Speed (USB3.0).
Device Connection Status	Read Only	It is the device connection status.
Device Link Throughput Limit Mode	Read & Write	It controls if the Device Link Throughput Limit is active. When disabled, lower level TL specific features are expected to control the throughput. When enabled, Device Link Throughput Limit controls the overall throughput.
Device Link Throughput Limit (Bps)	Read & Write	It limits the maximum bandwidth of the data that will be streamed out by the device on the selected link. If necessary, delays will be uniformly inserted between transport layer packets in order to control the peak bandwidth.
Device Link Current Throughput	Read Only	It is the current transmission bandwidth.
Device Command Timeout	Read Only	If the device has no response after this time, the device is disconnected or command timeout.
Device Sensor Throughput Limit	Read & Write	It controls device flow, and can be set according to actual bandwidth to avoid image lose.

Parameter	Read/Write	Description
Device Stream Channel Count	Read Only	It is the quantity of device stream channel.
Device Reset	Read & Write	Click Execute to reset the device.
Device Temperature Selector	Read & Write	It selects device component temperature.
Device Temperature	Read Only	It displays the temperature of the device component you selected.
Find Me	Read & Write	Click Execute to let red indicator flash once, and find device.
Device Max Throughput (bps)	Read Only	It is the maximum flow of device operation.
Device PJ Number	Read Only	It is the device's project number.
HB Abnormal Monitor	Read Only	It monitors image stream condition.
HB Version	Read Only	It is the version of the image compression mode.

13.2 Embedded Information

The device supports embedding information into image data. The information will be embedded into the image according to the enabling condition of each type of information in the order of the image embedding information listed in the table below.

Note

- The white balance is only available for the color device.
- The Width, Height, Offset X, Offset Y, and Pixel Format are only available for the device that supports Chunk function.
- The image embedding information may differ by device model.

Table 13-2 Image Embedding Information

Image Embedding Information	Byte	Data Format
Timestamp	4	Refer to the figure below this table.
Gain	4	The 4 bytes are used to transfer the gain information. Each low 8 bits of the 4 valid data are combined to transfer the gain information. Value Range: 0 to 1023. High bits will be complemented with 0 automatically.
Exposure	4	4 bytes are combined to show the exposure time,

Image Embedding Information	Byte	Data Format
		and the unit is μs .
Brightness Info	4	It ranges from 0 to 4095. High bits will be complemented with 0 automatically.
White Balance	8	R/G/B occupies 2 bytes each. Value Range: 0 to 4095.
Frame Counter	4	It ranges from 0 to $2^{32}-1$.
Ext Trigger Count	4	It ranges from 0 to $2^{32}-1$.
Line Input Output	4	The 1 st byte is input, and each bit corresponds to 1 input. The 2 nd byte is output, 3 rd and 4 th bytes are reserved.
ROI Position	8	The starting coordinates occupy two bytes each with the column coordinates at the front and the row coordinates at the back. The length and width coordinates each occupy two bytes.

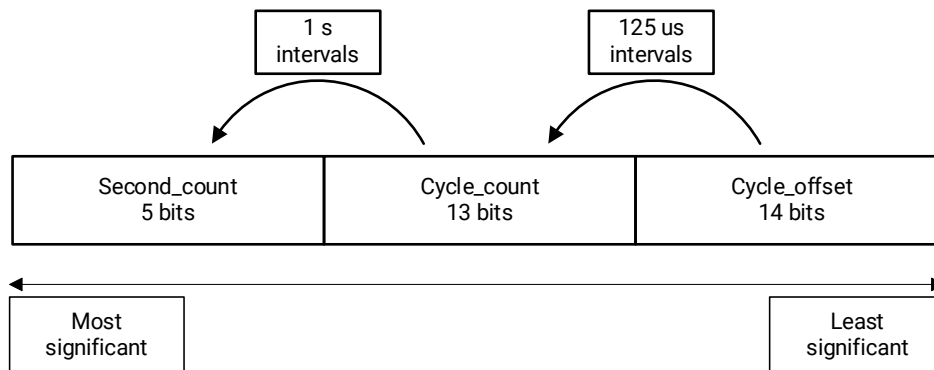

Figure 13-1 Data Format of Timestamp

There are two ways to embed information into the image, including watermark function and Chunk function.

Note

- Watermark function is not available if the device enables image compression mode.
- The watermark function or the Chunk function may differ by device models.
- The device uses Chunk function in priority if it supports both watermark and Chunk function.

13.2.1 Watermark Settings

Steps

1. Go to **Image Format Control** → **Embedded Image Info Selector**, and select **Embedded Image Info Selector** according to actual demands.

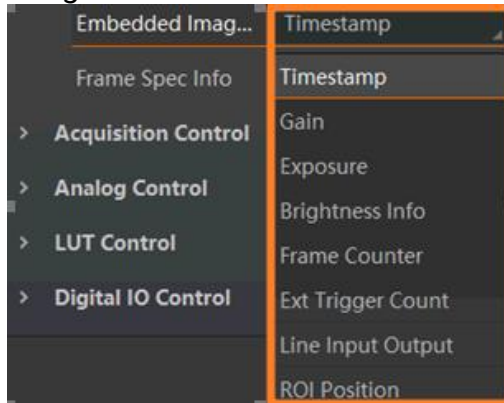

Figure 13-2 Select Embedded Image Information

2. Enable **Frame Spec Info** to add watermark into images.

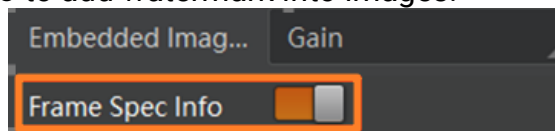



Figure 13-3 Add Embedded Image Information

3. (Optional) Repeat steps above to add multiple watermarks.
4. Click  on the control toolbar of the client software to view specific watermark information.

Note

The watermark is embedded into the starting position of the first line of image data. If the ROI is small and the first line of image data is insufficient to embed information, the information will be embedded into the second line of image data.

13.2.2 Chunk Settings

Steps

1. Go to **Chunk Data Control** → **Chunk Mode Active**, and enable **Chunk Mode Active**.

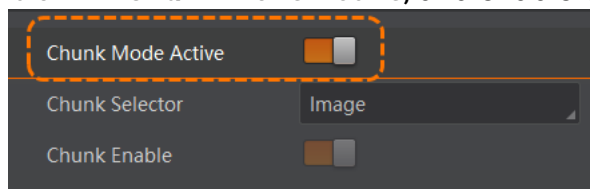

Figure 13-4 Enable Chunk Mode Active

2. Select **Chunk Selector** according to actual demands.

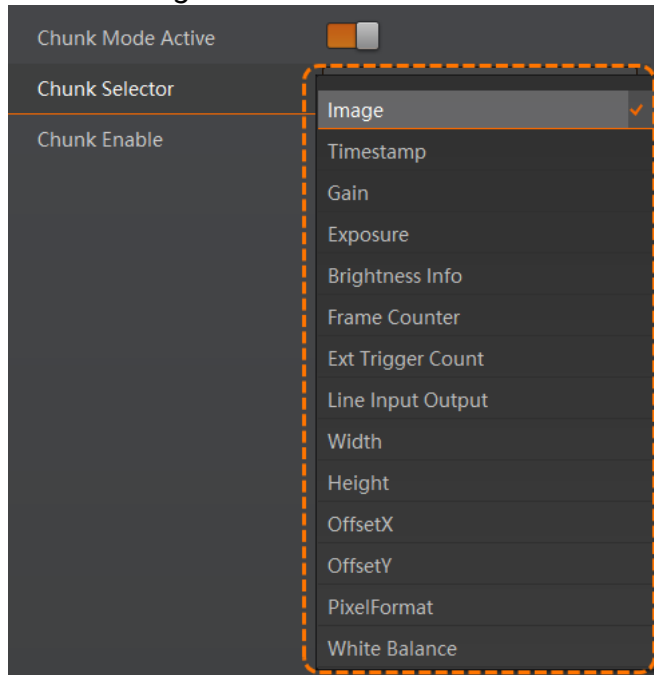

Figure 13-5 Select Embedded Image Information

3. Enable **Chunk Enable** to embed information into the image.

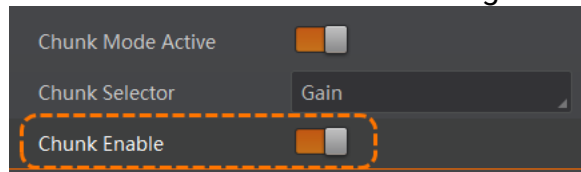

Figure 13-6 Chunk Enable

4. (Optional) Repeat steps above to add multiple Chunk information types.

5. Click  on the control toolbar of the client software to view specific information.

13.3 Event Control

Note

- The event control function may differ by device models or firmware.
 - The specific events may differ by device models.
-

The event control can record events happen to the device and allow you to view them.

Steps

1. Go to **Event Control** → **Event Selector**, and select **Event Selector** according to actual demands.

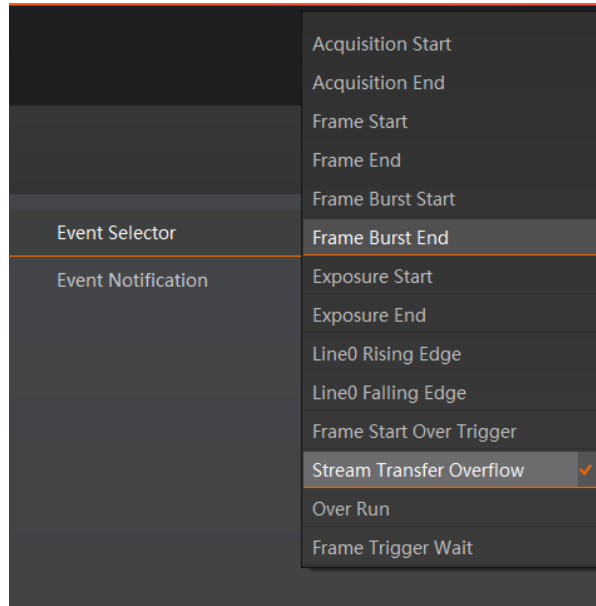

Figure 13-7 Event Selector

2. Select **Notification On** as **Event Notification** to output event.

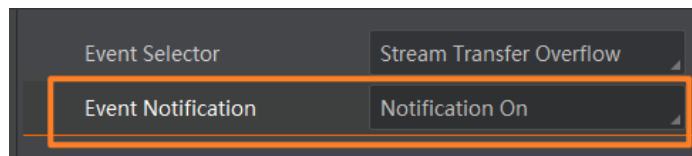

Figure 13-8 Set Event Control

3. Right click the connected device and click **Event Monitor**.

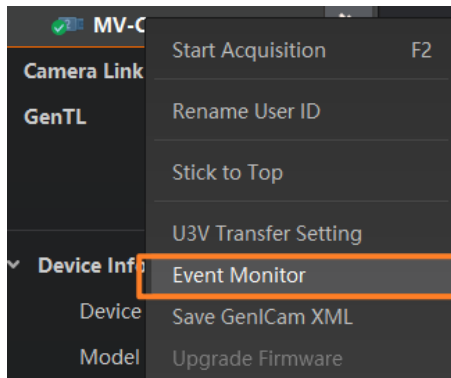

Figure 13-9 Event Monitor

4. Check **Messaging Channel Event**, and view the specific event after the device starts live view.

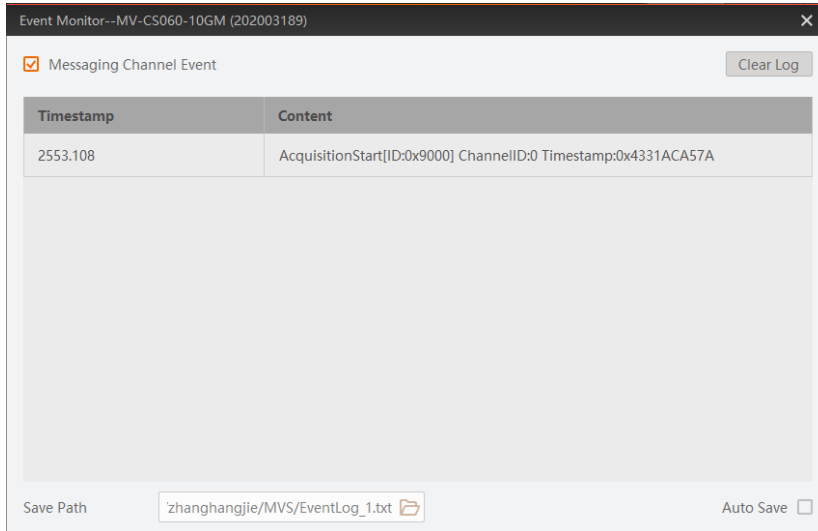

Figure 13-10 Event Monitor Window

13.4 Transport Layer Control

You can go to **Transport Layer Control** to view the device's payload size, GenCP version, etc.

Note

The specific parameters of transport layer control may differ by device models.

Table 13-3 Parameters of Transport Layer Control

Parameter	Read/Write	Description
Payload Size	Read Only	It is the device's load size.
GenCP Version Major	Read Only	It is the major version in GenCP version.
GenCP Version Minor	Read Only	It is the minor version in GenCP version.
U3V Version Major	Read Only	It is the major version in U3V version.
U3V Version Minor	Read Only	It is the minor version in U3V version.
U3VCP SIRM Available	Read Only	It sets whether the device supports one flow interface at least.
U3VCP EIRM Available	Read Only	It sets whether the device supports one event interface at least.
U3VCP IIDC2 Available	Read Only	It sets whether the device supports IIDC2 register mapping.
U3V Max Command	Read Only	It is the device max. command transmission length.

Parameter	Read/Write	Description
Transfer Length		
U3V Max Acknowledge Transfer Length	Read Only	It is the device max. data transmission length.
U3V Number Of Stream Channels	Read Only	It is the quantity of stream channel.
U3V SIRM Address	Read Only	It is the mapping address of SIRM.
U3V SIRM Length	Read Only	It is the length of each SIRM.
U3V EIRM Address	Read Only	It is the mapping address of EIRM.
U3V EIRM Length	Read Only	It is the length of each EIRM.
U3V Current Speed	Read Only	It is the current USB linking speed.

13.5 U3V Protocol Control

You can go to **Stream Control** to view USB transfer size, transfer times, final 1 value and final 2 value.

Note

The specific parameters of stream control may differ by device models.

Table 13-4 Parameters of Stream Control

Parameter	Read/Write	Description
U3V SI Payload Transfer Size	Read Only	It is the batch transmission size of stream data.
U3V SI Payload Transfer Count	Read Only	It is the batch transmission times of stream data.
U3V SI Payload FinalTransfer1 Size	Read Only	It is the Final 1 size of stream data.
U3V SI Payload FinalTransfer2 Size	Read Only	It is the Final 2 size of stream data.

13.6 Transfer Control

You can go to **Transfer Control** to view the device’s transfer sources, transfer mode, queue information, etc.

 **Note**

The specific parameters of transfer control may differ by device models.

13.6.1 User Controlled Transfer Control

The parameters of user controlled transfer control are shown below.

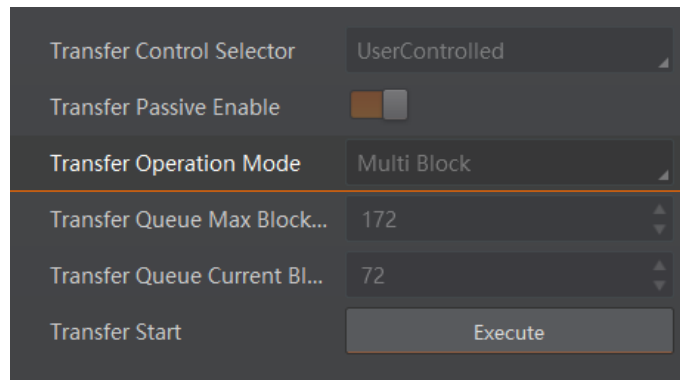



Figure 13-11 User Controlled Transfer Control

Table 13-5 Parameters of User Controlled Transfer Control

Parameter	Read/Write	Description
Transfer Control Selector	Read & Write	It selects the transfer mode. <ul style="list-style-type: none"> ● Basic: In this mode, the device sends images to the client software directly after acquiring images. ● UserControlled: In this mode, the device saves images in its internal cache first, and then sends to the client software after acquiring images.
Transfer Passive Enable	Read & Write	The transfer passive node will be displayed if it is enabled. <p> Note</p> <ul style="list-style-type: none"> ● You should select User Controlled as Transfer Control Selector first. ● Make sure that the device’s Trigger Mode is On.
Transfer Operation Mode	Read & Write	It is the transfer operation mode: <ul style="list-style-type: none"> ● Single Block: Click Execute in Transfer Start to

Parameter	Read/Write	Description
		let the device transfer one image each time. <ul style="list-style-type: none"> Multi Block: Click Execute in Transfer Start to let the device transfer multiple images in cache.
Transfer Queue Max Block Count	Read Only	It displays the max. image quantity that the device's memory can save before the compression.
Transfer Queue Current Block Count	Read Only	It displays current image quantity saved by the memory.
Transfer Start	Read and write	Click Execute to let the device transfer images.  Note It will be displayed when image acquisition is started.

13.6.2 Basic Transfer Control

 **Note**

The device supporting image compression mode has parameters of basic transfer control.

The parameters of basic transfer control are shown below.

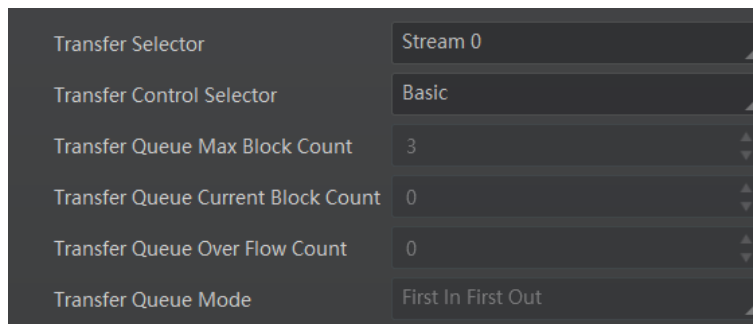

Figure 13-12 Basic Transfer Control

Table 13-6 Parameters of Basic Transfer Control

Parameter	Read/Write	Description
Transfer Selector	Read & Write	It selects the transfer source.
Transfer Control Selector	Read & Write	It selects the transfer mode.
Transfer Queue Max Block Count	Read Only	It displays the max. image quantity that the device's memory can save before the compression.

Parameter	Read/Write	Description
Transfer Queue Current Block Count	Read Only	It displays current image quantity saved by the memory.
Transfer Queue Over Flow Count	Read & Write	It is the image quantity discarded by FPGA.
Transfer Queue Mode	Read & Write	It is the operating mode of memory queue.

13.7 File Access Control

Note

The file access control function may differ by device model.

The file access function can import or export the device's feature files and save them in mfa format. The supported feature files include User Set 1/2/3, DPC, LUT Luminance 1/2/3, and License Notice.

Steps

1. Select a device in the device list, and click  to open the file access dialogue box.

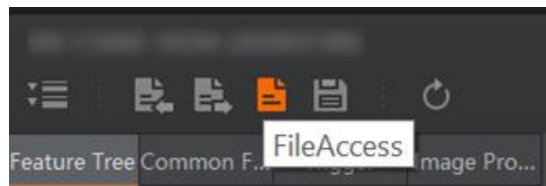

Figure 13-13 File Access

2. Select **Device Feature** and click **Import** or **Export**.

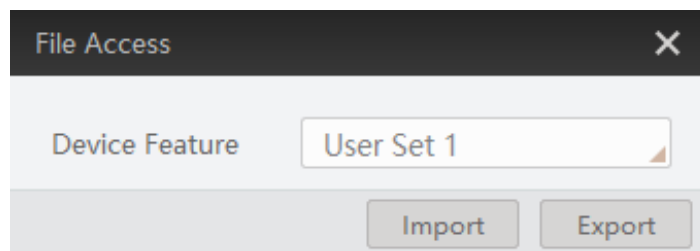

Figure 13-14 Import or Export

3. Select a file in MFA format from local PC to import, or select a saving path and enter file name to save and export.

Note

- Importing and exporting the device feature among the same model and same firmware of devices are supported.
- If **User Set 1/2/3** is selected as device feature, you need to load the corresponding user

set you selected to take effect.

- If **LUT Luminance 1/2/3** is selected as device feature, it will take effect only when you select the same parameters in LUT Selector.
- DPC means defect pixel correction. If the DPC is selected as device feature, it will take effect immediately after importing.
- **License Notice** supports exporting only.

13.8 Update Firmware

The device supports updating firmware via the USB3.0 cable and MVS Tool Kit.

Note

The MVS Tool Kit is installed by default when you install the MVS client software.

Steps

1. Go to **Tool** → **Toolkit** → **Firmware Upgrade Tool** to open the MVS Tool Kit.
2. Select **Camera** in the **Select Type**. The tool will automatically refresh and show all enumerated devices.

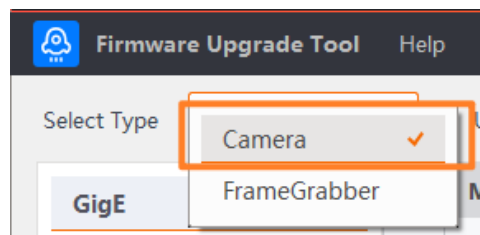



Figure 13-15 Select Camera

3. Select the device in available status to update.
4. Click  to select firmware upgrade package (dav file).
5. Click **Update** to start updating.

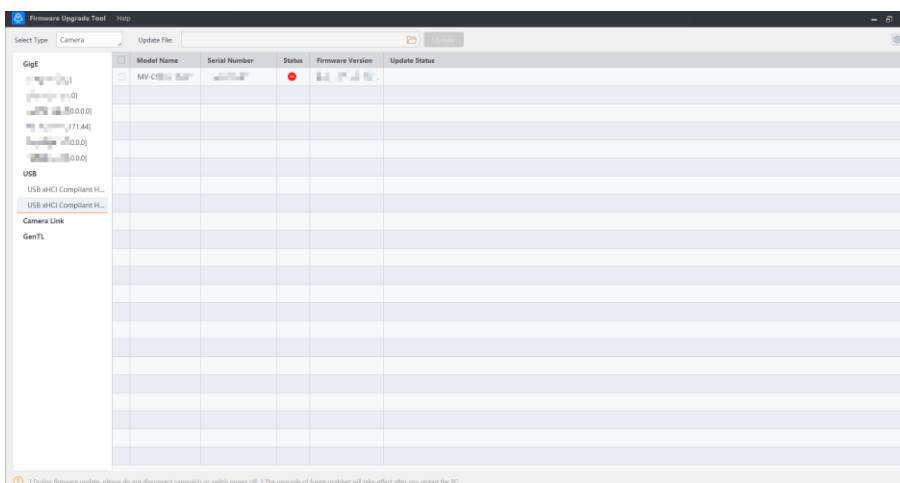

Figure 13-16 Update Firmware

Note

- The device will restart automatically after updating the firmware.
 - The firmware updating process may take a few minutes, please wait patiently.
 - During firmware updating, do not disconnect the device or switch power off, otherwise it may cause device damage.
-

Chapter 14 FAQ (Frequently Asked Question)

14.1 Why the client software cannot list devices?

Table 14-1 Question 1

Possible Cause	Solution
The device is not powered on.	Check the device's power supply connection by observing the device's indicator, and check USB cable connection.
Incorrect USB cable connection.	

14.2 Why device connection fails after the device is listed in the client software?

Table 14-2 Question 2

Possible Cause	Solution
Incorrect installation of the client software.	Install the client software again.
The USB3.0 driver is not installed successfully.	Check the USB driver, and reinstall the driver if it is required.

14.3 Why the live view is black?

Table 14-3 Question 3

Possible Cause	Solution
The device's lens aperture is not removed.	Remove the device's lens aperture.
The device exception occurs.	Power off and restart the device.

14.4 Why the device cannot be triggered although the live view is normal?

Table 14-4 Question 4

Possible Cause	Solution
The trigger mode is not enabled or the device is not triggered.	Enable the trigger mode and make sure that the selected trigger source matches with the corresponding I/O signal.
Incorrect trigger wiring.	Check if the input of trigger signal and wiring are correct or not.

14.5 Why the device cannot get images required by the algorithm although live view and trigger signal are normal?

Table 14-5 Question 5

Possible Cause	Solution
Incorrect output format of images.	Check the image format required by the algorithm, and adjust the output format of images in the client software.

14.6 Why the device is offline during using?

Table 14-6 Question 6

Possible Cause	Solution
The connection of the USB interface is unstable.	<ul style="list-style-type: none"> ● It is not recommended to use the adapter to connect the device for data transmission. ● It is recommended to use the DC power supply. Refer to the device's specification for the voltage range.
The cable is inappropriate.	
There is electrostatic and electromagnetic interference.	

Chapter 15 Revision History

Table 15-1 Revision History

Version	Document No.	Revision Date	Revision Details
V3.0.0	UD42620B	May 19, 2025	Edit the whole content and structure.
V2.3.1	UD31198B	Dec. 5, 2022	<ul style="list-style-type: none"> ● Add Section Set Super Bayer. ● Edit Section Set Binning. ● Edit Section Set Gamma Correction. ● Edit Section Set Sharpness. ● Edit Section Set Contrast Ratio. ● Edit Section Set Super Palette Control. ● Edit Section Set LUT.
V2.3.0	UD30198B	Sep. 16, 2022	<ul style="list-style-type: none"> ● Edit Section Safety Instructions. ● Edit Section Set Pixel Format. ● Add Section Set Sequencer Control and HDR. ● Edit Section Transfer Control.
V2.2.0	UD28477B	May. 13, 2022	<ul style="list-style-type: none"> ● Edit Section Appearance. ● Edit Section I/O Connector and Indicator. ● Add Section Set Overlap Mode. ● Edit Section Enable Strobe Signal. ● Edit Section Set Analog Gain. ● Add Section Set Contrast Ratio. ● Add Section Set Super Platte Control.
V2.1.0	UD22554B	Jan. 4, 2021	<ul style="list-style-type: none"> ● Edit Section Appearance. ● Edit Section Enable Strobe Signal. ● Add Section Set Image Compression Mode. ● Add Section Set Digital Noise Reduction. ● Add Section Set Color Adjustment. ● Edit Section Device Control. ● Add Section Transfer Control.
V1.6.1	UD21438B	Sep. 21, 2020	<ul style="list-style-type: none"> ● Add Section Overview. ● Edit Section Appearance. ● Edit Section Check Driver. ● Add Section Sensor Shutter Mode. ● Edit Section Set External Trigger Source. ● Add Section Set Anyway Trigger. ● Edit Section Enable Strobe Signal. ● Edit Section Set Pixel Format. ● Edit Section Test Pattern. ● Add Section Exposure Time Mode. ● Add Section U3V Protocol Control.

USB3.0 Area Scan Camera User Manual

Version	Document No.	Revision Date	Revision Details
V1.0.0	UD13016B	Jan. 9, 2019	Original version.

Appendix A Device Parameter Index

Here list all parameters of the device mentioned in different sections of this user manual. You can quickly locate parameters in different sections by viewing tables below.

A.1 Device Control

Table A-1 Device Control

Parameters	Section
Device Scan Type	Section Device Control
Device Vendor Name	
Device Model Name	
Device Manufacturer Info	
Device Version	
Device Firmware Version	
Device Serial Number	
Device User ID	
Maximum Device Response Time	
Device Manifest Table Address	
Device SBRM Address	
Device Timestamp	
Device Timestamp Latch	
Device Timestamp Increment	
Device Protocol Endianness	
Device Implementation Endianness	
Device Uptime(s)	
Board Device Type	
USB Interface Selector	
USB Speed Mode	

Parameters	Section
Device Connection Status	
Device Link Throughput Limit Mode	
Device Link Throughput Limit(Bps)	
Device Link Current Throughput	
Device Command Timeout	
Device Stream Channel Count	
Device Reset	
Device Temperature Selector	
Device Temperature	
Fine Me	
Device Max Throughput(bps)	
Device PJ Number	
HB Abnormal Monitor	
HB Version	

A.2 Image Format Control

Table A-2 Image Format Control

Parameters	Section
Width Max	Section Set Resolution and ROI
Height Max	
Region Selector	
Region Destination	
Width	
Height	
Offset X	
Offset Y	
Reverse X	Section Set Image Reverse

Parameters	Section
Reverse Y	
ADC Bit Depth	Section Set Pixel Format
Pixel Format	
Super Bayer Enable	
Pixel Size	
Image Compression Mode	Section Set Image Compression Mode
High Bandwidth Mode	
Test Pattern Generator Selector	Section Set Test Pattern
Test Pattern	
Binning Mode	Section Set Binning
Binning Selector	
Binning Horizontal	
Binning Vertical	
Decimation Horizontal	Section Set Decimation
Decimation Vertical	
Embedded Image Info Selector	Section Embed Information into Image
Frame Spec Info	

A.3 Acquisition Control

Table A-3 Acquisition Control

Parameters	Section
Acquisition Mode	Section Set Acquisition Mode
Acquisition Start	
Acquisition Stop	
Acquisition Burst Frame Count	Section Set Frame Rate
Acquisition Frame Rate	
Acquisition Frame Rate Control Enable	

Parameters	Section
Resulting Frame Rate	
Reference Frame Rate	
Overlap Mode	Set Non-Overlap Exposure and Overlap Exposure
Trigger Selector	Section Set Trigger Source
Trigger Mode	
Trigger Software	
Trigger Source	
Trigger Activation	
Trigger Delay(μ s)	
Trigger Cache Enable	
Sensor Shutter Mode	Section Rolling Shutter
Exposure Mode	Section Set Exposure Mode
Exposure Time Mode	
Exposure Time	
Exposure Auto	
Auto Exposure Time Lower Limit(μ s)	
Auto Exposure Time Upper Limit(μ s)	
HDR Enable	Section Set HDR
HDR Selector	
HDR Shutter(μ s)	
HDR Gain	
WDR Mode	Section Set WDR Mode
WDR Level	

A.4 Analog Control

Table A-4 Analog Control

Parameters	Section
Preamp Gain	Section Set Gain
Gain(dB)	
Gain Auto	
Auto Gain Lower Limit(dB)	
Auto Gain Upper Limit(dB)	
Digital Shift	
Digital Shift Enable	
Sensor Mode	Section Set Sensor Mode
Brightness	Section Set Brightness
Black Level	Section Set Black Level
Black Level Enable	
Balance White Auto	Section Set White Balance
AWB Color Temperature Mode	
Balance Ratio Selector	
Balance Ratio	
Gamma	Section Set Gamma Correction
Gamma Selector	
Gamma Enable	
Sharpness	Section Set Sharpness
Sharpness Enable	
Sharpness Auto	
Digital Noise Reduction Mode	Section Set Digital Noise Reduction
Denoise Strength	
Noise Correct	

Parameters	Section
Contrast Ratio	Section Set Contrast Ratio
Contrast Ratio Enable	
Auto Function AOI Selector	Section Set AOI
Auto Function AOI Width	
Auto Function AOI Height	
Auto Function AOI OffsetX	
Auto Function AOI OffsetY	
Auto Function AOI Usage Intensity	
AutoF Function AOI Usage White Balance	

A.5 Color Transformation Control

Table A-5 Color Transformation Control

Parameters	Section
CCM Enable	Section Set Color Transformation Control
Color Transformation Selector	
Color Transformation Enable	
Color Transformation Value Selector	
Color Transformation Value	
Hue	Section Set Hue
Hue Enable	
Saturation	Section Set Saturation
Saturation Enable	

A.6 Super Palette Control

Table A-6 Super Palette Control

Parameters	Section
Super Palette Enable	Section Set Super Palette Control
Super Palette Selector	
Super Palette Hue	
Super Palette Saturation	

A.7 LUT Control

Table A-7 LUT Control

Parameters	Section
LUT Selector	Section Set LUT
LUT Enable	
LUT Index	
LUT Value	
LUT Save	

A.8 Shading Correction

Table A-8 Shading Correction

Parameters	Section
NUC Enable	Section Set Shading Correction
FPNC Enable	
PRNUC Enable	
Shading Selector	
LSC Calib Select	
LSC Target Gray	

Parameters	Section
Activate Shading	
LSC Enable	

A.9 Digital I/O Control

Table A-9 Digital I/O Control

Parameters	Section
Line Selector	Section Trigger Output
Line Mode	
Line Inverter	
Line Status	
Line Status All	
Line Debouncer Time	
Line Source	
Strobe Enable	
Strobe Line Duration	
Strobe Line Delay (μs)	
Strobe Line Pre Delay (μs)	

A.10 Counter and Timer Control

Table A-10 Counter and Timer Control

Parameters	Section
Counter Selector	Section Trigger Source
Counter Event Source	
Counter Reset Source	
Counter Reset	
Counter Value	
Counter Current Value	

A.11 File Access Control

Table A-11 File Access Control

Parameters	Section
File Selector	Section File Access Control
File Operation Selector	
File Operation Execute	
File Open Mode	
File Operation Status	
File Operation Result	
File Size(B)	

A.12 Sequencer Control

Table A-12 Sequencer Control

Parameters	Section
Sequencer Mode	Section Set Sequencer
Sequencer Configuration Mode	
Sequencer Feature Selector	
Sequencer Feature Enable	
Sequencer Restart	
Sequencer Set Total Number	
Sequencer Set Selector	
Sequencer Set Active	
Sequencer Set Load	
Sequencer Set Save	

A.13 Event Control

Table A-13 Event Control

Parameters	Section
Event Selector	Section Event Control
Event Notification	

A.14 Chunk Data Control

Table A-14 Chunk Data Control

Parameters	Section
Chunk Mode Active	Section Chunk Settings
Chunk Selector	
Chunk Enable	

A.15 Transport Layer Control

Table A-15 Transport Layer Control

Parameters	Section
Payload Size	Section Transport Layer Control
GenCP Version Major	
GenCP Version Minor	
U3V Version Major	
U3V Version Minor	
U3VCP SIRM Available	
U3VCP EIRM Available	
U3VCP IIDC2 Available	
U3V Max Command Transfer Length	
U3V Max Acknowledge Transfer Length	
U3V Number Of Stream Channels	
U3V SIRM Address	

Parameters	Section
U3V SIRM Length	
U3V EIRM Address	
U3V EIRM Length	
U3V Current Speed	

A.16 Stream Control

Table A-16 Stream Control

Parameters	Section
U3V SI Payload Transfer Size	Section U3V Protocol Control
U3V SI Payload Transfer Count	
U3V SI Payload FinalTransfer1 Size	
U3V SI Payload FinalTransfer2 Size	

A.17 Transfer Control

Table A-17 Transfer Control

Parameters	Section
Transfer Control Mode	Section Transfer Control
Transfer Passive Enable	
Transfer Operation Mode	
Transfer Start	
Transfer Selector	
Transfer Control Selector	
Transfer Queue Max Block Count	
Transfer Queue Current Block Count	
Transfer Queue Over Flow Count	
Transfer Queue Mode	

A.18 User Set Control

Table A-18 User Set Control

Parameters	Section
User Set Current	Section User Set Customization
User Set Selector	
User Set Load	
User Set Save	
User Set Save Status	
User Set Default	



HIKROBOT

SHAPE OUR FUTURE INTELLIGENTLY

Hikrobot Co., Ltd.

Tel: 400-989-7998

Website: <https://en.hikrobotics.com/>

UD42620B